



Warmth on the farm

Great for dairies and animal shelters. The **FUHGX5T** has been designed and built in accordance with the highest of standards regarding the installation of farm heaters. All aspects of its construction contribute to its high level of safety.

{features}

color	almond
finish	satincoat steel cabinet, coated with a high-quality epoxy powder paint making it 10 times more resistant to corrosion
manufacturing	<ul style="list-style-type: none"> robust, 18-gauge satincoat steel cabinet five adjustable louvers and safety wire mesh accessible thermal protection with manual reset pilot light indicating when thermal protection has been activated easy access junction box
wattage & voltage	see the selection table
element	<ul style="list-style-type: none"> nickel-plated and sealed with silicone to prevent corrosion low-density element maintains the cabinet temperature lower than that of a conventional heater
motor	lubricated for life, totally enclosed ball bearing motor
fan	<ul style="list-style-type: none"> fan switch permits the unit to operate as a fan only fan delay allows the unit to cool down before actually shutting off
control	double pole built-in thermostat (included)
installation	wall or ceiling with universal mounting bracket (included)
warranty	<ul style="list-style-type: none"> 5 years (element) 1 year (unit)

{selection table}

product code	power	voltage	phase	power	weight	
	watts	volts	nb.	btu/h	kg	lb
FUHGX5T	5000/3750	240/208	1	17065/ 12798	18	40

{technical drawing}

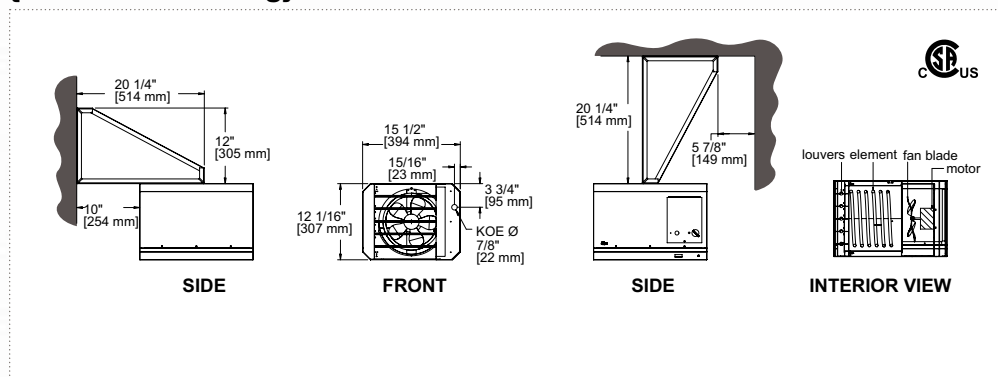

corrosive and moisture
this unit is intended for use in category 1 and 2*

element
low-density helps to keep cabinet temperature lower

motor
lubricated for life, totally enclosed ball bearing motor

louvers
five adjustable louvers and safety wire mesh

universal mounting bracket
wall or ceiling mounted (included)

* location in which corrosive liquids or vapours or excessive moisture are likely to be present. (section 22-002 of the Canadian Electrical Code)

FUHGX