

Stelpro baseboard heater

Designed for safety, comfort and performance, the Stelpro baseboard heater has brought a new dimension to the electrical heating world as we know it. By virtue of its unique design, safety is no longer compromised with this state-of-the-art heater.

Sharp edges have been eliminated and replaced by soft, aesthetically rounded, durable steel end caps.

Our standard white and almond colors, with their baked enamel finish, blend in harmoniously with any decor.



{features}

color	white (W) or almond (A)
finish	top quality 100% polyester paint, baked enamel, glossy finish
manufacturing	<ul style="list-style-type: none"> · 22-gauge steel casing able to support 22 kg in its center · 16-gauge steel connection boxes at each end · full-length thermal protection with automatic reset · diffuser located above the element in order to ensure good air diffusion · full-length wireway · steel end caps with soft, rounded corners
wattage & voltage	see the selection table
element	<ul style="list-style-type: none"> · single tubular, stainless steel sheathed element with boxed aluminum fins for improved heat dissipation · securely fastened at its center, floating in nylon sleeves at each end, eliminating expansion and contraction noises
control	<ul style="list-style-type: none"> · built-in thermostat may be installed at either end (not included) · wall thermostat (not included) · built-in relay may be installed in left end only - optional (not included)
installation	<ul style="list-style-type: none"> · surface mount · BX & NMD cable clamps (included) · mounting holes spaced at 1-inch intervals along the top and the bottom of the unit · knockouts conveniently located at the back of the heater, and at each end
warranty	· lifetime (element), 1 year (unit)

{accessories}

code	description
N1T1*	built-in single pole thermostat (120, 208, 240, 277 or 347 V units)
N2T1*	built-in double pole thermostat (120, 208, 240 or 277 V units)
N2T1TP*	built-in tamper-proof double pole thermostat (120, 208, 240, 277 or 347 V units)
N2T16*	built-in double pole thermostat (600 V units)
NRE153*	built-in electronic low voltage relay [15 A @ 120, 208, 277 or 347 V]
NRE156*	built-in electronic low voltage relay [6 A @ 600 V]
NRE153T*	built-in electronic low voltage relay c/w transformer 24 V [15 A @ 208, 277 or 347 V]
NR841C1151*	built-in mechanical low voltage relay c/w transformer 24 V [6000 W @ 600 V]
NO*	duplex outlet section [15 A @ 120 V]
NS*	switch section [15 A @ 240 V]
NOS*	switch on/on & single outlet section [15 A @ 240 V]
NC*	corner section (3 x 3 in.)
NP*	spray paint white or almond

* add W for white or A for almond

* factory installed

electronic relays can receive a pulsed or on/off signal



Clamp for BX cable from wall (277 to 600V)



Clamp for BX cable from floor (277 to 600V)



Clamp for NMD cable (120 to 208 and 240 V)

{technical drawing}

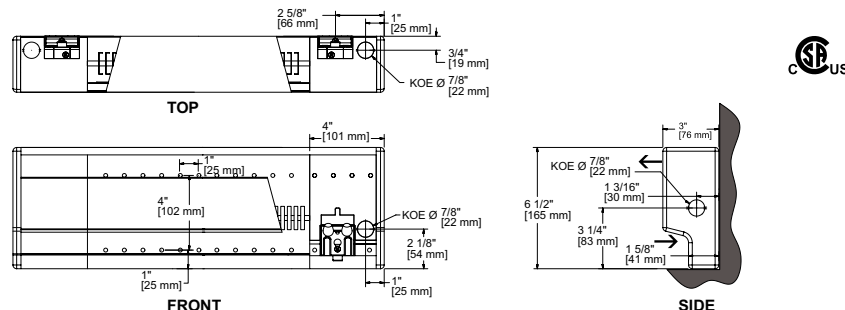

low density
on 208 V or 240 V circuits (see the selection table)



pages 90 to 96
wall thermostats & accessories

{selection table}

250 W density per linear foot	power	voltage	width		weight	
code	watts	volts	mm	in.	kg	lb
N3V1	300	120	505	19 7/8	2.0	5
N3V8	300	208	505	19 7/8	2.0	5
N3V2	300/225	240/208	505	19 7/8	2.0	5
---	300	277/240/208	505	19 7/8	2.0	5
---	300	347	505	19 7/8	2.0	5
---	300	480	505	19 7/8	2.0	5
---	300	600	505	19 7/8	2.0	5
N5V1	500	120	708	27 7/8	3.0	7
N5V8	500	208	708	27 7/8	3.0	7
N5V2	500/375	240/208	708	27 7/8	3.0	7
N5V7	500/375/280	277/240/208	708	27 7/8	3.0	7
N5V3	500	347	708	27 7/8	3.0	7
---	500	480	708	27 7/8	3.0	7
---	500	600	708	27 7/8	3.0	7
N7V1	750	120	956	37 5/8	4.1	9
N7V8	750	208	956	37 5/8	4.1	9
N7V2	750/560	240/208	956	37 5/8	4.1	9
N7V7	750/560/425	277/240/208	956	37 5/8	4.1	9
N7V3	750	347	956	37 5/8	4.1	9
N7V5	750	480	956	37 5/8	4.1	9
N7V6	750	600	956	37 5/8	4.1	9
N10V1	1000	120	1207	47 1/2	5.1	11
N10V8	1000	208	1207	47 1/2	5.1	11
N10V2	1000/750	240/208	1207	47 1/2	5.1	11
N10V7	1000/750/565	277/240/208	1207	47 1/2	5.1	11
N10V3	1000	347	1207	47 1/2	5.1	11
N10V5	1000	480	1207	47 1/2	5.1	11
N10V6	1000	600	1207	47 1/2	5.1	11
N12V1	1250	120	1454	57 1/4	6.2	14
N12V8	1250	208	1454	57 1/4	6.2	14
N12V2	1250/940	240/208	1454	57 1/4	6.2	14
N12V7	1250/940/705	277/240/208	1454	57 1/4	6.2	14
N12V3	1250	347	1454	57 1/4	6.2	14
N12V5	1250	480	1454	57 1/4	6.2	14
N12V6	1250	600	1454	57 1/4	6.2	14
N15V1	1500	120	1683	66 1/4	7.2	16
N15V8	1500	208	1683	66 1/4	7.2	16
N15V2	1500/1125	240/208	1683	66 1/4	7.2	16
N15V7	1500/1125/845	277/240/208	1683	66 1/4	7.2	16
N15V3	1500	347	1683	66 1/4	7.2	16
N15V5	1500	480	1683	66 1/4	7.2	16
N15V6	1500	600	1683	66 1/4	7.2	16
---	1750	120	1930	76	8.2	18
N17V8	1750	208	1930	76	8.2	18
N17V2	1750/1315	240/208	1930	76	8.2	18
N17V7	1750/1300/985	277/240/208	1930	76	8.2	18
N17V3	1750	347	1930	76	8.2	18
N17V5	1750	480	1930	76	8.2	18
N17V6	1750	600	1930	76	8.2	18
---	2000	120	2130	83 7/8	9.1	20
N20V8	2000	208	2130	83 7/8	9.1	20
N20V2	2000/1500	240/208	2130	83 7/8	9.1	20
N20V7	2000/1500/1125	277/240/208	2130	83 7/8	9.1	20
N20V3	2000	347	2130	83 7/8	9.1	20
N20V5	2000	480	2130	83 7/8	9.1	20
N20V6	2000	600	2130	83 7/8	9.1	20
---	2250	120	2381	93 3/4	10.2	22
N22V8	2250	208	2381	93 3/4	10.2	22
N22V2	2250/1690	240/208	2381	93 3/4	10.2	22
N22V7	2250/1690/1265	277/240/208	2381	93 3/4	10.2	22
N22V3	2250	347	2381	93 3/4	10.2	22
N22V5	2250	480	2381	93 3/4	10.2	22
N22V6	2250	600	2381	93 3/4	10.2	22
---	2500	120	2607	102 5/8	11.1	24
N25V8	2500	208	2607	102 5/8	11.1	24
N25V2	2500/1875	240/208	2607	102 5/8	11.1	24
N25V7	2500/1875/1405	277/240/208	2607	102 5/8	11.1	24
N25V3	2500	347	2607	102 5/8	11.1	24
N25V5	2500	480	2607	102 5/8	11.1	24
N25V6	2500	600	2607	102 5/8	11.1	24

add **W** for white or **A** for almond

to get a low density baseboard on a 240 V circuit, use 277 V models. The power (wattage) difference between the 277 V and the 240 V is less than 25 %.

to get a low density baseboard on a 208 V circuit, use 240 V models. The power (wattage) difference between the 240 V and the 208 V is less than 25 %.

--- not available