

{vertical unit heater}

A unit heater that recycles

The **VUH** vertical unit heater is not only a large heat source, it is also a unit heater that recycles the residual heat that stagnates at the ceiling level.

With the air intake at its sides, the **VUH** draws in the warm air at the ceiling and re-directs it where it is needed most. Ideally suited for areas such as factories and warehouses with high ceilings, the **VUH** is perfect for those high heat loss shopping mall entrance ways. A fan switch transforms this heater into a fan which recycles warm air.



triple cone unit (optional cone)

{features}

color	almond
finish	epoxy-polyester powdercoat
manufacturing	<ul style="list-style-type: none"> heavy-duty, 16-gauge steel cabinet three sizes of cone diffusers available for better air distribution thermal protection with automatic reset
motor	totally enclosed with ball bearings
wattage & voltage	see the selection table
element	tubular element sheathed with spiral-wound fins for improved heat dissipation
control	<ul style="list-style-type: none"> 240 V control circuit all units have factory installed contactors
installation	<ul style="list-style-type: none"> four 1/2 in. mounting holes for threaded rods (13-thread) (5 to 10 kW units) four eyebolts for chain suspension (15 to 60 kW units)
warranty	1 year

{accessories}

code	description
VUHFS	fan switch
VUHJC1	diffuser jet cone (VUH1)
VUHJC2	diffuser jet cone (VUH2)
VUHJC3	diffuser jet cone (VUH3)

cone diffusers

three sizes of cone diffusers available for better air distribution



pages 90 to 96
wall thermostats & accessories



{selection table}

240 V contactor	24 V control	120 V control	power	voltage	phase	power	flow	motor
code	code	code	kW	volts	nb.	btu/h	cfm	hp
VUH0531C	VUH0531C24	VUH0531C120	5	347	1	17060	450	1/25
VUH0563C	VUH0563C24	VUH0563C120	5	600	3	17060	450	1/25
VUH0731C	VUH0731C24	VUH0731C120	7.5	347	1	17060	600	1/25
VUH0763C	VUH0763C24	VUH0763C120	7.5	600	3	25590	600	1/25
VUH1031C	VUH1031C24	VUH1031C120	10	347	1	34120	750	1/25
VUH1063C	VUH1063C24	VUH1063C120	10	600	3	34120	750	1/25
VUH1563C	VUH1563C24	VUH1563C120	15	600	3	51180	1200	1/8
VUH2063C	VUH2063C24	VUH2063C120	20	600	3	68240	1600	1/8
VUH2563C	VUH2563C24	VUH2563C120	25	600	3	85300	2000	1/8
VUH3063C	VUH3063C24	VUH3063C120	30	600	3	102300	2300	1/8
VUH4063C	VUH4063C24	VUH4063C120	40	600	3	136500	4000	3/4
VUH5063C	VUH5063C24	VUH5063C120	50	600	3	176050	4000	3/4
VUH6063C	VUH6063C24	VUH6063C120	60	600	3	204720	4800	3/4

{cone diffusers}

produit	nb	unit	weight		surface A		surface B	
code	cone	kW	kg	lb	m	ft	m	ft
---	without cone	5-10	34.0	75	3.7	12	5.8	19
---	without cone	15-30	47.6	105	6.1	20	8.3	27
---	without cone	40-60	90.7	200	9.1	30	14.0	46
VUHSC1	single	5-10	34.0	75	3.1	10	6.9	22
VUHSC2	single	15-30	47.6	105	3.7	12	9.5	31
VUHSC3	single	40-60	90.7	200	4.9	16	10.0	33
VUH3C1	triple	5-10	34.0	75	3.1	10	9.5	31
VUH3C2	triple	15-30	47.6	105	4.2	15	14.0	46
VUH3C3	triple	40-60	90.7	200	6.1	20	15.0	49
VUH4C1	quadruple	5-10	34.0	75	3.1	10	10.4	34
VUH4C2	quadruple	15-30	47.6	105	4.2	15	15.3	50
VUH4C3	quadruple	40-60	90.7	200	6.1	20	17.1	56

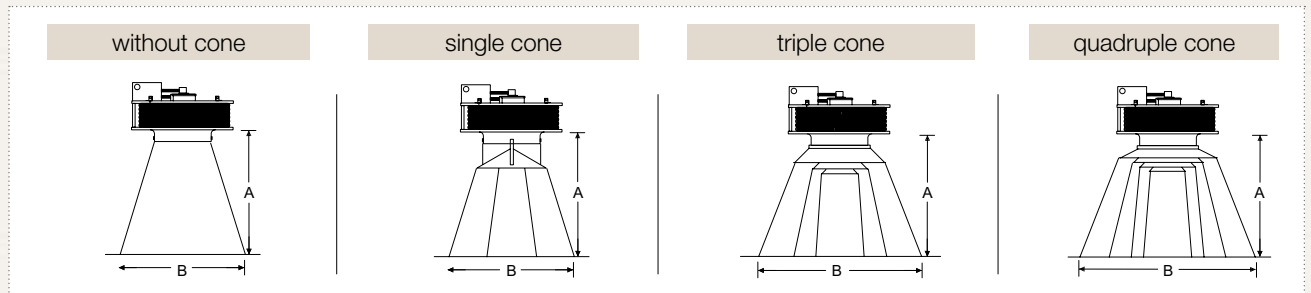

{technical drawings}

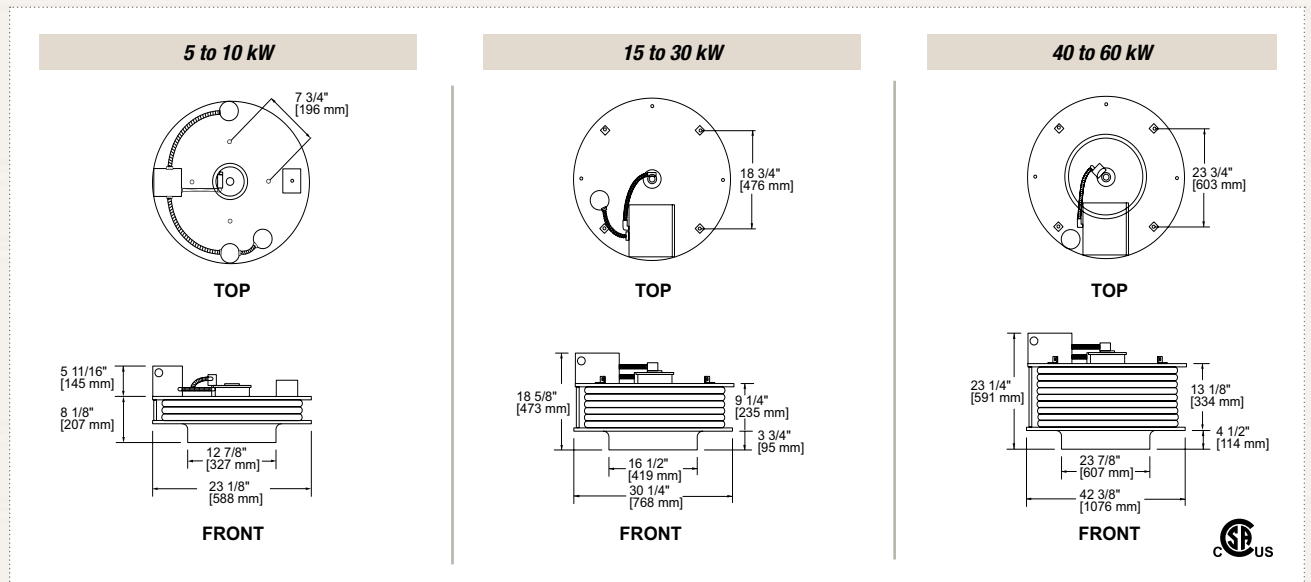

VUH