

**La chaleur des grands espaces**

Puisqu'il est robuste et facile à installer, l'aérotherme SHU est l'appareil idéal pour chauffer de grands espaces tels que des garages, des entrepôts et des immeubles commerciaux à grande surface.

Une vaste gamme de puissance allant de 2 kW à 60 kW ainsi que trois formats de boîtiers sont offerts.



**{caractéristiques}**

<b>couleur</b>	amande
<b> finition</b>	peinture en poudre d'époxy-polyester
<b> fabrication</b>	<ul style="list-style-type: none"> <li>boîtier d'acier robuste de calibre 18</li> <li>louveres ajustables et grillage de sécurité</li> <li>protection thermique à réenclenchement automatique</li> </ul>
<b> moteur</b>	<ul style="list-style-type: none"> <li>lubrifié à vie avec coussinets (unités de 10 kW ou moins)</li> <li>lubrifié à vie sur roulement à billes (unités de 15 kW ou plus)</li> </ul>
<b> puissance et tension</b>	voir le tableau de sélection
<b> élément</b>	alliage nickel-chrome de grande qualité assurant une chaleur instantanée
<b> contrôle</b>	voir le tableau de sélection
<b> installation</b>	<ul style="list-style-type: none"> <li>murale ou au plafond à l'aide du support de montage universel (compris)</li> <li>distance minimale du plancher :                             <ul style="list-style-type: none"> <li>- 8 pi (unités de 2 à 10 kW)</li> <li>- 10 pi (unités de 15 à 30 kW)</li> <li>- 15 pi (unités de 40 à 60 kW)</li> </ul> </li> <li>distance minimale des murs adjacents :                             <ul style="list-style-type: none"> <li>- 6 po (unités de 2 à 30 kW)</li> <li>- 12 po (unités de 40 à 60 kW)</li> </ul> </li> </ul>
<b> garantie</b>	<ul style="list-style-type: none"> <li>- 10 ans (élément)</li> <li>- 1 an (appareil)</li> </ul>

**{accessoires}**

code	description
SHUT1	thermostat intégré unipolaire (capillaire)
SHUT2	thermostat intégré bipolaire (capillaire)
SHUFS*	interrupteur de ventilateur
SHUDIS*	interrupteur principal [80 A]

\* installation en usine

**{dessins techniques}**

2 à 10 kw

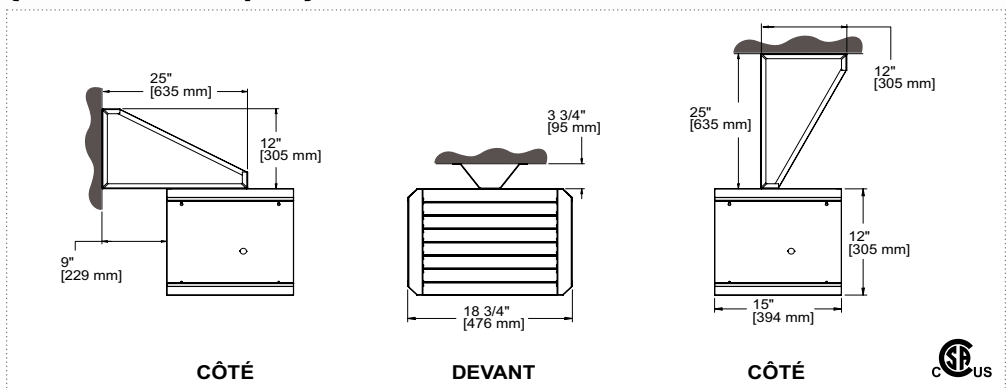

**support universel**  
installation au mur ou au plafond (compris)



**électricité vs gaz**  
1 kW = 3414 btu/h



**pages 90 à 96**  
thermostats muraux et accessoires



{tableau de sélection}

Sans contrôle	Thermostat intégré	Contacteur 240 V	Contacteur & th. intégré 240 V	Contrôle 24 V			
code	code	code	code	code	kW	volts	pcm
SHU0281	SHU0281T	SHU0281C	---	SHU0281C24	2	208	250
---	---	SHU0283C*	SHU0283CT*	SHU0283C24*	2	208	250
SHU0221	SHU0221T	SHU0221C	---	SHU0221C24	2	240	250
SHU0271	SHU0271T	SHU0271C	---	SHU0271C24	2	277	250
---	---	SHU0231C	SHU0231CT	SHU0231C24	2	347	250
---	---	SHU0251C	SHU0251CT	SHU0251C24	2	480	250
---	---	SHU0253C*	SHU0253CT*	SHU0253C24*	2	480	250
---	---	SHU0261C	SHU0261CT	SHU0261C24	2	600	250
---	---	SHU0263C*	SHU0263CT*	SHU0263C24*	2	600	250
SHU0381	SHU0381T	SHU0381C	---	SHU0381C24	3	208	250
---	---	SHU0383C*	SHU0383CT*	SHU0383C24*	3	208	250
SHU0321	SHU0321T	SHU0321C	---	SHU0321C24	3	240	250
SHU0371	SHU0371T	SHU0371C	---	SHU0371C24	3	277	250
---	---	SHU0331C	SHU0331CT	SHU0331C24	3	347	250
---	---	SHU0351C	SHU0351CT	SHU0351C24	3	480	250
---	---	SHU0353C*	SHU0353CT*	SHU0353C24*	3	480	250
---	---	SHU0361C	SHU0361CT	SHU0361C24	3	600	250
---	---	SHU0363C*	SHU0363CT*	SHU0363C24*	3	600	250
SHU0481	SHU0481T	SHU0481C	---	SHU0481C24	4	208	250
---	---	SHU0483C*	SHU0483CT*	SHU0483C24*	4	208	250
SHU0421	SHU0421T	SHU0421C	---	SHU0421C24	4	240	250
SHU0471	SHU0471T	SHU0471C	---	SHU0471C24	4	277	250
---	---	SHU0431C	SHU0431CT	SHU0431C24	4	347	250
---	---	SHU0451C	SHU0451CT	SHU0451C24	4	480	250
---	---	SHU0453C*	SHU0453CT*	SHU0453C24*	4	480	250
---	---	SHU0461C	SHU0461CT	SHU0461C24	4	600	250
---	---	SHU0463C*	SHU0463CT*	SHU0463C24*	4	600	250
---	SHU0581T	SHU0581C	---	SHU0581C24	5	208	450
---	---	SHU0583C*	SHU0583CT*	SHU0583C24*	5	208	450
SHU0521	SHU0521T	SHU0521C	---	SHU0521C24	5	240	450
SHU0571	SHU0571T	SHU0571C	---	SHU0571C24	5	277	450
---	---	SHU0531C	SHU0531CT	SHU0531C24	5	347	450
---	---	SHU0551C	SHU0551CT	SHU0551C24	5	480	450
---	---	SHU0553C*	SHU0553CT*	SHU0553C24*	5	480	450
---	---	SHU0561C	SHU0561CT	SHU0561C24	5	600	450
---	---	SHU0563C*	SHU0563CT*	SHU0563C24*	5	600	450
---	---	SHU0781C	SHU0781CT	SHU0781C24	7,5	208	700
---	---	SHU0783C*	SHU0783CT*	SHU0783C24*	7,5	208	700
---	---	SHU0721C	SHU0721CT	SHU0721C24	7,5	240	700
---	---	SHU0771C	SHU0771CT	SHU0771C24	7,5	277	700
---	---	SHU0731C	SHU0731CT	SHU0731C24	7,5	347	700
---	---	SHU0751C	SHU0751CT	SHU0751C24	7,5	480	700
---	---	SHU0753C*	SHU0753CT*	SHU0753C24*	7,5	480	700
---	---	SHU0761C	SHU0761CT	SHU0761C24	7,5	600	700
---	---	SHU0763C*	SHU0763CT*	SHU0763C24*	7,5	600	700

\* appareil triphasé modifiable en monophasé sur le chantier  
 \* appareil triphasé  
 --- non disponible

Sans contrôle	Thermostat intégré	Contacteur 240 V	Contacteur & th. intégré 240 V	Contrôle 24 V			
code	code	code	code	code	kW	volts	pcm
---	---	SHU1081C	SHU1081CT	SHU1081C24	10	208	700
---	---	SHU1083C*	SHU1083CT*	SHU1083C24*	10	208	700
---	---	SHU1021C	SHU1021CT	SHU1021C24	10	240	700
---	---	SHU1071C	SHU1071CT	SHU1071C24	10	277	700
---	---	SHU1031C	SHU1031CT	SHU1031C24	10	347	700
---	---	SHU1051C	SHU1051CT	SHU1051C24	10	480	700
---	---	SHU1053C*	SHU1053CT*	SHU1053C24*	10	480	700
---	---	SHU1061C	SHU1061CT	SHU1061C24	10	600	700
---	---	SHU0763C*	SHU1063CT*	SHU0763C24*	10	600	700
---	---	SHU1581C	SHU1581CT	SHU1581C24	15	208	1300
---	---	SHU1583C*	SHU1583CT*	SHU1583C24*	15	208	1300
---	---	SHU1521C	SHU1521CT	SHU1521C24	15	240	1300
---	---	SHU1571C	SHU1571CT	SHU1571C24	15	277	1300
---	---	SHU1531C	SHU1531CT	SHU1531C24	15	347	1300
---	---	SHU1551C	SHU1551CT	SHU1551C24	15	480	1300
---	---	SHU1553C*	SHU1553CT*	SHU1553C24*	15	480	1300
---	---	SHU1561C	SHU1561CT	SHU1561C24	15	600	1300
---	---	SHU1563C*	SHU1563CT*	SHU1563C24*	15	600	1300
---	---	SHU2081C	SHU2081CT	SHU2081C24	20	208	1300
---	---	SHU2083C*	SHU2083CT*	SHU2083C24*	20	208	1300
---	---	SHU2021C	SHU2021CT	SHU2021C24	20	240	1300
---	---	SHU2071C	SHU2071CT	SHU2071C24	20	277	1300
---	---	SHU2031C	SHU2031CT	SHU2031C24	20	347	1300
---	---	SHU2051C	SHU2051CT	SHU2051C24	20	480	1300
---	---	SHU2053C*	SHU2053CT*	SHU2053C24*	20	480	1300
---	---	SHU2063C*	SHU2063CT*	SHU2063C24*	20	600	1300
---	---	SHU2583C*	SHU2583CT*	SHU2583C24*	25	208	1300
---	---	SHU2553C*	SHU2553CT*	SHU2553C24*	25	480	1300
---	---	SHU2563C*	SHU2563CT*	SHU2563C24*	25	600	1400
---	---	SHU3083C*	SHU3083CT*	SHU3083C24*	30	208	1400
---	---	SHU3053C*	SHU3053CT*	SHU3053C24*	30	480	1400
---	---	SHU3063C*	SHU3063CT*	SHU3063C24*	30	600	1400
---	---	SHU4053C*	SHU4053CT*	SHU4053C24*	40	480	2100
---	---	SHU4063C*	SHU4063CT*	SHU4063C24*	40	600	2100
---	---	SHU5053C*	SHU5053CT*	SHU5053C24*	50	480	2100
---	---	SHU5063C*	SHU5063CT*	SHU5063C24*	50	600	2100
---	---	SHU6053C*	SHU6053CT*	SHU6053C24*	60	480	2100
---	---	SHU6063C*	SHU6063CT*	SHU6063C24*	60	600	2100

SHU

{dessins techniques} (suite)

15 à 30 kw

40 à 60 kw

