

L'air forcé en plusieurs dimensions

Étant l'un des appareils de chauffage électrique des plus polyvalents, le **WF** s'installe au mur ou en surface et s'encastre.

Il est idéal pour les espaces commerciaux, les vestibules et les garages qui nécessitent une grande puissance. Puisque plusieurs puissances et formats sont offerts, il constitue une solution efficace pour une multitude d'applications.

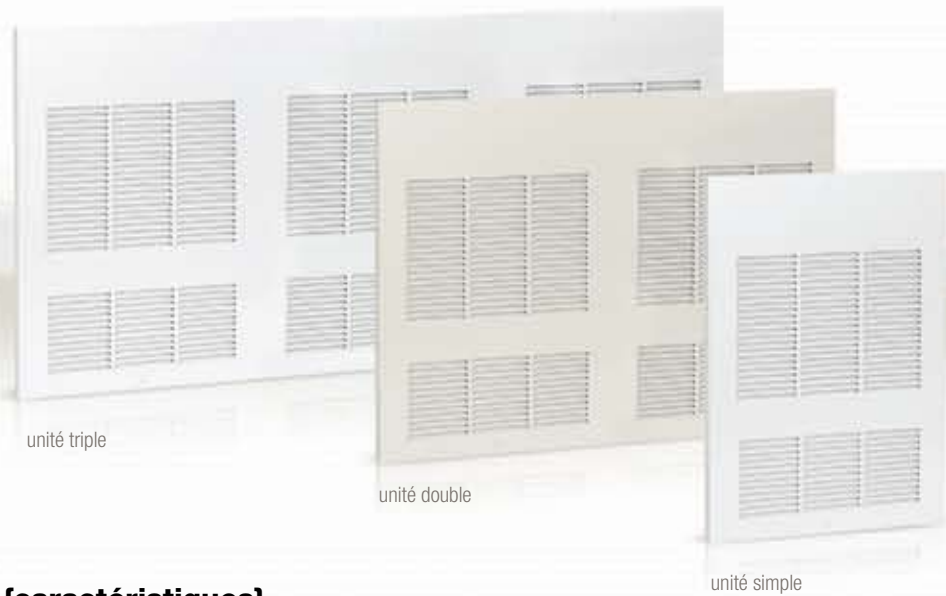

{caractéristiques}

couleur	blanc (W) ou amande (A)
 finition	peinture en poudre d'époxy-polyester
 fabrication	<ul style="list-style-type: none"> boîtier d'acier de calibre 20 grilles de calibre 18 l'air entre par le haut de l'appareil et en sort par le bas ventilateur : <ul style="list-style-type: none"> - 1 x 160 pcm (unité simple) - 2 x 160 pcm (unité double) - 3 x 160 pcm (unité triple) protection thermique à réencenchement automatique
 puissance et tension	voir le tableau de sélection
 élément	alliage nickel-chrome de grande qualité assurant une chaleur instantanée
 installation	<ul style="list-style-type: none"> murale encastrée ou en surface avec boîtier de surface - facultatif (non compris)
 garantie	<ul style="list-style-type: none"> 10 ans (élément) 1 an (appareil)

{accessoires}

code	description
WFT1	thermostat intégré unipolaire
WFT2	thermostat intégré bipolaire
WFA1*	boîtier de surface (unité simple)
WFA2*	boîtier de surface (unité double)
WFA3*	boîtier de surface (unité triple)

* ajouter **W** pour blanc ou **A** pour amande

{dessins techniques}

unité simple

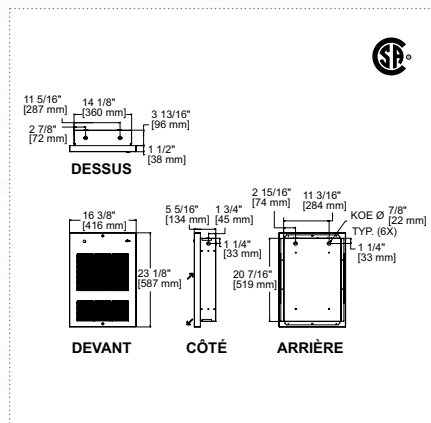

unité double

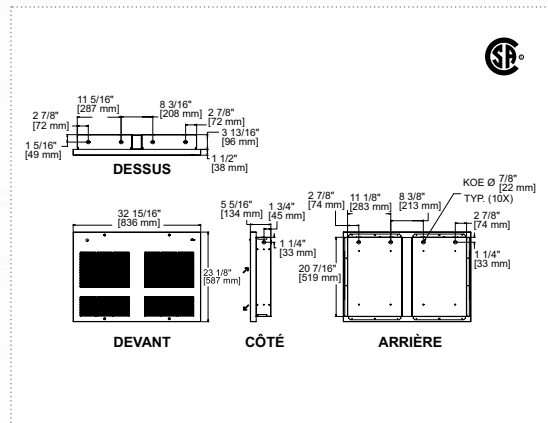

pages 90 à 96
thermostats muraux et accessoires

approuvé selon les **normes canadiennes** seulement

{tableau de sélection}

sans contrôle	thermostat intégré	contacteur 240 V	contacteur 240 V & thermostat intégré	contrôle 24 V	puissance	tension	poids		modèle
code	code	code	code	code	watts	volts	kg	lb	unité
WF1502	WF1502T	WF1502C	---	WF1502C24	1500/1125	240/208	9	20	simple
WF1508	WF1508T	WF1508C	---	WF1508C24	1500	208	9	20	simple
WF1507	WF1507T	WF1507C	---	WF1507C24	1500	277	9	20	simple
---	WF1503T	WF1503C	---	WF1503C24	1500	347	9	20	simple
---	WF1505T	WF1505C	---	WF1505C24	1500	480	9	20	simple
---	WF1506T	WF1506C	---	WF1506C24	1500	600	10	22	simple
WF2002	WF2002T	WF2002C	---	WF2002C24	2000/1500	240/208	9	20	simple
WF2008	WF2008T	WF2008C	---	WF2008C24	2000	208	9	20	simple
WF2007	WF2007T	WF2007C	---	WF2007C24	2000	277	9	20	simple
---	WF2003T	WF2003C	---	WF2003C24	2000	347	9	20	simple
---	WF2005T	WF2005C	---	WF2005C24	2000	480	9	20	simple
---	WF2006T	WF2006C	---	WF2006C24	2000	600	10	22	simple
WF3002	WF3002T	WF3002C	---	WF3002C24	3000/2250	240/208	9	20	simple
WF3008	WF3008T	WF3008C	---	WF3008C24	3000	208	9	20	simple
WF3007	WF3007T	WF3007C	---	WF3007C24	3000	277	9	20	simple
---	WF3003T	WF3003C	---	WF3003C24	3000	347	9	20	simple
---	WF3005T	WF3005C	---	WF3005C24	3000	480	9	20	simple
---	WF3006T	WF3006C	---	WF3006C24	3000	600	10	22	simple
WF4002	WF4002T	WF4002C	---	WF4002C24	4000/3000	240/208	9	20	simple
WF4008	WF4008T	WF4008C	---	WF4008C24	4000	208	9	20	simple
WF4007	WF4007T	WF4007C	---	WF4007C24	4000	277	9	20	simple
---	WF4003T	WF4003C	---	WF4003C24	4000	347	9	20	simple
---	WF4005T	WF4005C	---	WF4005C24	4000	480	9	20	simple
---	WF4006T	WF4006C	---	WF4006C24	4000	600	10	22	simple
---	WF6002T	WF6002C	---	WF6002C24	6000/4500	240/208	18	40	double
---	---	WF6008C	WF6008CT	WF6008C24	6000	208	18	40	double
---	WF6007T	WF6007C	---	WF6007C24	6000	277	18	40	double
---	WF6003T	WF6003C	---	WF6003C24	6000	347	18	40	double
---	WF6005T	WF6005C	---	WF6005C24	6000	480	20	44	double
---	WF6006T	WF6006C	---	WF6006C24	6000	600	20	44	double
---	---	WF60083C*	WF60083CT*	WF60083C24*	6000	208	36	80	triple
---	---	WF60053C*	WF60053CT*	WF60053C24*	6000	480	36	80	triple
---	---	WF60063C*	WF60063CT*	WF60063C24*	6000	600	36	80	triple
---	---	WF8002C	WF8002CT	WF8002C24	8000/6000	240/208	18	40	double
---	---	WF8008C	WF8008CT	WF8008C24	8000	208	18	40	double
---	---	WF8007C	WF8007CT	WF8007C24	8000	277	18	40	double
---	---	WF8003C	WF8003CT	WF8003C24	8000	347	18	40	double
---	---	WF8005C	WF8005CT	WF8005C24	8000	480	20	44	double
---	---	WF8006C	WF8006CT	WF8006C24	8000	600	20	44	double
---	---	WF90083C*	WF90083CT*	WF90083C24*	9000	208	36	80	triple
---	---	WF90053C*	WF90053CT*	WF90053C24*	9000	480	36	80	triple
---	---	WF90063C*	WF90063CT*	WF90063C24*	9000	600	36	80	triple
---	---	WF12002C	WF12002CT	WF12002C24	12000/9000	240/208	36	80	triple
---	---	WF12008C	WF12008CT	WF12008C24	12000	208	36	80	triple
---	---	WF12007C	WF12007CT	WF12007C24	12000	277	36	80	triple
---	---	WF12003C	WF12003CT	WF12003C24	12000	347	36	80	triple
---	---	WF12005C	WF12005CT	WF12005C24	12000	480	36	80	triple
---	---	WF12006C	WF12006CT	WF12006C24	12000	600	36	80	triple
---	---	WF120083C*	WF120083CT*	WF120083C24*	12000	208	36	80	triple
---	---	WF120053C*	WF120053CT*	WF120053C24*	12000	480	36	80	triple
---	---	WF120063C*	WF120063CT*	WF120063C24*	12000	600	36	80	triple

ajouter W pour blanc ou A pour amande

* appareil triphasé

--- non disponible

{dessins techniques}

unité triple

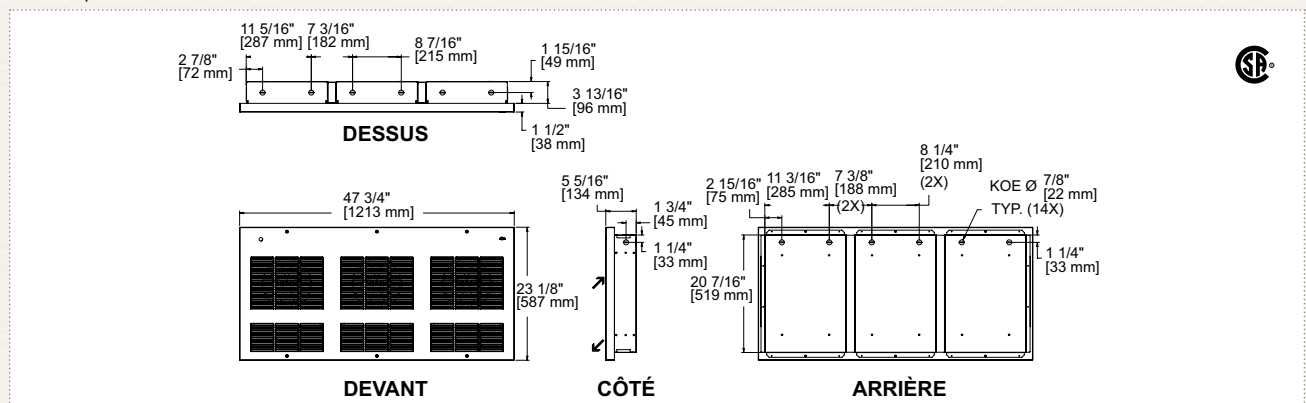

WF