

DESSINS TECHNIQUES | TECHNICAL DRAWINGS

UNITÉS DE 2 KW À 10 KW | 2 KW TO 10 KW UNITS

poids : env. 40 lb (18 kg) | weight: approx. 40 lb (18 kg)

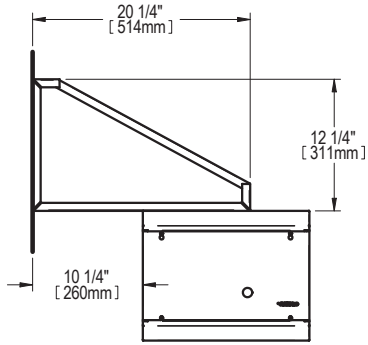

CÔTÉ GAUCHE | LEFT SIDE

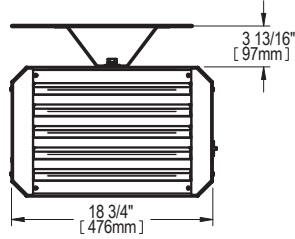

DEVANT | FRONT

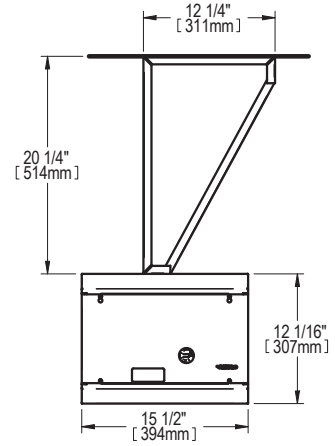

CÔTÉ DROIT | RIGHT SIDE

UNITÉS DE 15 KW À 30 KW | 15 KW TO 30 KW UNITS

poids : env. 67 lb (30 kg) | weight: approx. 67 lb (30 kg)

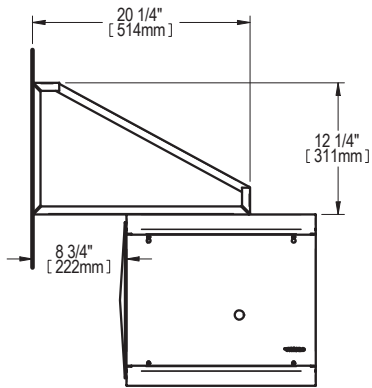

CÔTÉ GAUCHE | LEFT SIDE

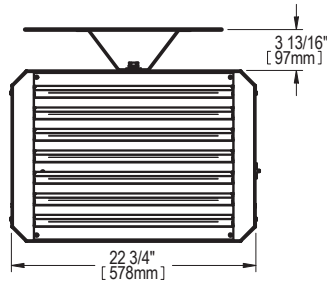

DEVANT | FRONT

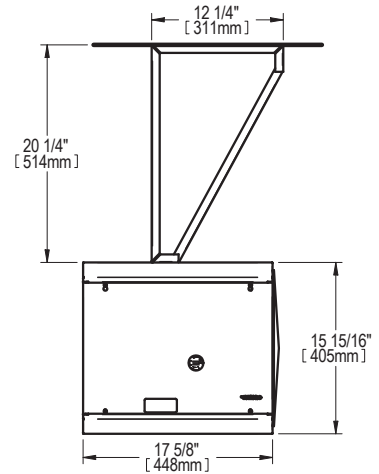

CÔTÉ DROIT | RIGHT SIDE

UNITÉS DE 40 KW À 60 KW | 40 KW TO 60 KW UNITS

poids : env. 100 lb (45 kg) | weight: approx. 100 lb (45 kg)

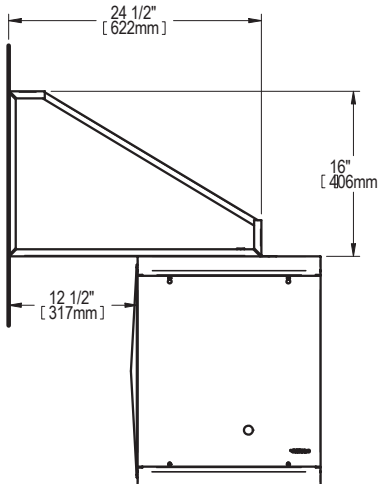

CÔTÉ GAUCHE | LEFT SIDE

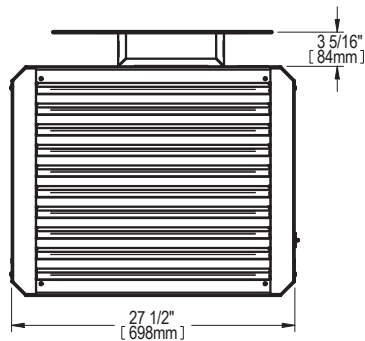

DEVANT | FRONT

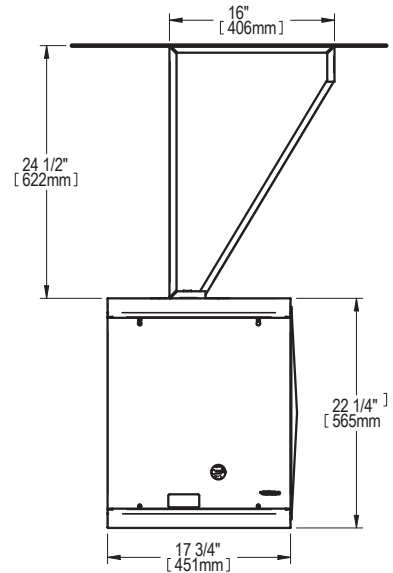

CÔTÉ DROIT | RIGHT SIDE