

EC22

AIR CURTAIN FOR SMALL ENTRANCES



FRICO



IP20



EFFICIENT SOLUTION FOR SMALL ENTRANCES

Equipped with an energy-efficient EC motor and smart control, the EC22 air curtain is ideal for small entrances, vestibules, and commercial spaces. With its optimized airflow and optional electric heating, it ensures effective climate separation while reducing operating costs.

- **ENERGY-SAVING THERMAL BARRIER**
- **SLEEK, CLEAN DESIGN**
- **CAN/CSA AND UL CERTIFIED**
- **HIGH-EFFICIENCY EC MOTOR**
- **AMCA LAB-TESTED (SOUND & PERFORMANCE)**

COLOURS

- **standard** : stainless steel housing, white (RAL 9016, NCS S 0500-N).
- grille, rear face and ends grey: (RAL 7046)
- other colors available on special order (not part of the Orora program)

MODEL

- electric heat
- no heat

MANUFACTURING

- quick access to internal components via the maintenance hatch
- high-limit temperature control with automatic reset
- integrated transformer for motor and control circuit (480V and 600V models)

VOLTAGE

- 208V, 480V, 600V, 60 Hz

MOTOR

- very low operating costs can be achieved thanks to the combination of EC motors and Frico's unique fan geometry

FAN

- squirrel-cage fans

ELEMENT

- element provides instant heat (electric heat model)

CONTROL

- integrated control system and additional easy to use remote control
- door switch included

INSTALLATION

- maximum height installation: 7.2 ft. (2.2 m) above the floor
- suspended mounting:
 - with pendulum brackets included: 4 brackets for 1m and 1.5m models and 6 brackets for 2m models
 - with threaded rods (not included)

Note: The recommended installation height may vary according to the installation conditions. Air curtains must be placed as near to the entrance as possible and cover the entire width.

CERTIFICATION

- CAN/CSA-E60335-2-30:13 (R2018)
- UL 2021 Ed. 4.0
- protection class for units with electrical heating: IP20
- protection class for units without heating: IP21

WARRANTY

- 5-year warranty against defects

IDEAL FOR:

small entrances, vestibule, commercial building, lobby, service door, hospital, store entrance, drive-through, service counters

°**STELPRO**

Stelpro reserves the right to modify at any time the description, manufacturing, or price of its products. Additionally, Stelpro may apply restocking fees or refuse a refund based on one or more of the following criteria: optional color, custom product, assembly with low-demand options. For the latest product information and prices regarding the products, please visit the website www.stelpro.com.

TECHNICAL SPECIFICATIONS

PRODUCT		VOLTAGE	kW	INPUT POWER MOTOR	AMP.	CFM	dBA*	EFFECTIVE AIR WIDTH		WEIGHT	
CODE	PRICE	VOLTS (1PH)	Lo/Hi	HP	-	-	-	IN.	MM	LB	KG
SURFACE-MOUNTED ELECTRIC HEAT (IP20)											
PAEC2210CE05-600VNA	4 536.00	600 (3)	3.3/5	1/8	5.4	765	70	30.5	777.24	42.1	19.1
PAEC2215CE08-600VNA	4 985.00	600 (3)	4/8	1/8	8.6	1265	72	50.7	1287.78	61.9	28.1
PAEC2220CE10-600VNA	7 682.00	600 (3)	5/10	1/8	10.6	1471	73	67.4	1711.96	79.6	36.1
PAEC2210CE05-480VNA	4 435.00	480 (3)	3.3/5	1/8	6.6	765	70	30.5	777.24	41.4	18.8
PAEC2215CE08-480VNA	5 047.00	480 (3)	4/8	1/8	10.5	1265	72	50.7	1287.78	61.3	27.8
PAEC2220CE10-480VNA	7 671.00	480 (3)	5/10	1/8	13	1471	73	67.4	1711.96	78.9	35.8
PAEC2210CE04-208VNA	4 138.00	208 (3)	2.7/4.1	1/8	11.9	765	70	30.5	777.24	37.5	17.0
PAEC2215CE07-208VNA	4 592.00	208 (3)	3.2/6.5	1/8	18.9	1265	72	50.7	1287.78	57.3	26.0
PAEC2220CE08-208VNA	7 458.00	208 (3)	4.1/8.1	1/8	23.5	1471	73	67.4	1711.96	75	34.0
SURFACE-MOUNTED NO HEAT (IP21)											
PAEC2210CA-NA	3 179.00	208 (1)	-	-	0.6	765	70	30.5	777.24	35.3	16.0
PAEC2215CA-NA	3 746.00	208 (1)	-	-	0.9	1265	72	50.7	1287.78	52.9	24.0
PAEC2220CA-NA	5 226.00	208 (1)	-	-	1.0	1471	73	67.4	1711.96	70.5	32.0

To order any custom colors from the R.A.L. chart, add "SP" at the end of the Product # and specify RAL color # on the order. When ordering a different color, inquire about delivery times and prices. Contact our customer service department for lead times.

*Sound pressure (dBA) Conditions: Distance to the unit 5 m. Directional factor: 2. Equivalent absorption area: 200 m². At highest air flow.

ACCESSORIES

PRODUCT	DESCRIPTION	QUANTITY INCLUDED	LENGTH		PRICE
			IN.	MM	
PA3PF15	Ceiling mounting brackets for 1 and 1.5 m units	4	8.25	210	127.12
PA3PF20	Ceiling mounting brackets for 2 m units	6	8.25	210	175.56
PA2P15	Hanging brackets for 1 and 1.5 m units	2	39	1000	126.21
PA2P20	Hanging brackets for 2 m units	3	39	1000	171.88

TECHNICAL DRAWINGS

All models

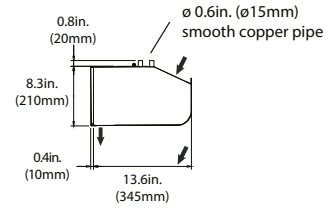
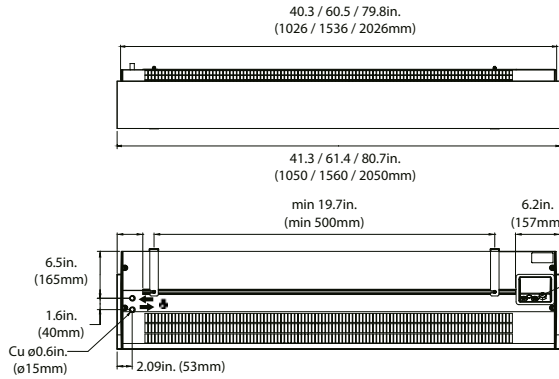

78.7in. (2m) units

