

User's guide

“CH” series Kick space heater

Replacement component list included

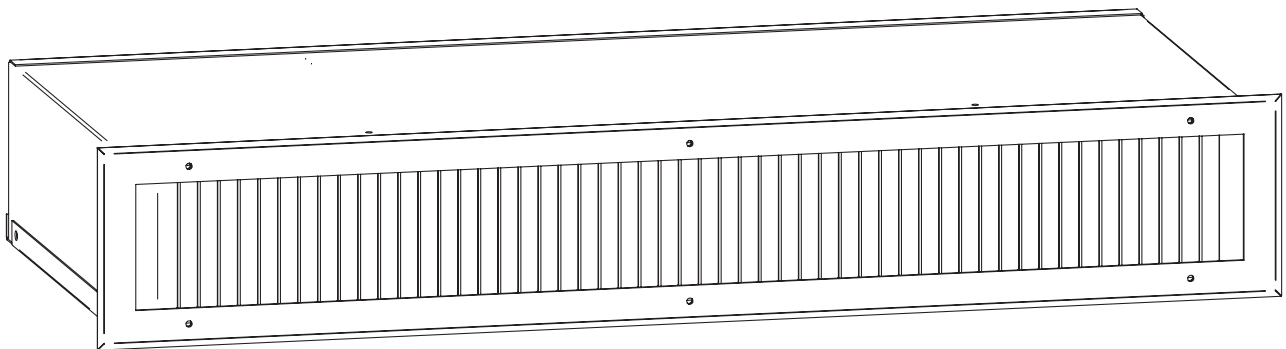

This unit complies with
the CSA and UL standards

WARNING **WARNING** **WARNING** **WARNING**

Before installing and operating this product, the user and/or installer must read, understand and follow these instructions and keep them handy for future reference. If these instructions are not followed, the warranty will be considered null and void and the manufacturer deems no further responsibility for this product.

This product must be installed by a qualified person and connected by a **certified electrician**, according to the **electrical and building codes** effective in your region.

The following instructions must be adhered to in order to avoid personal injuries or property damages, serious injuries and potentially fatal electric shocks.

Protect the heating unit with the appropriate circuit breaker or fuse, in accordance with the nameplate.

Make sure the line voltage (volt) is consistent with that indicated on the unit's nameplate.

This unit must be **grounded**.

Switch off the power at the circuit breaker/fuse before installing, repairing and cleaning the unit.

For further information or to consult this guide online, please visit our Web site.

Make sure the unit is appropriate for the intended use (if needed, refer to the product catalog or a representative).

Recommended heating capacity:

1.25 W/cubic foot (0.03 m³).

It corresponds to **10 W/square foot (0.09 m²)** based on a standard ceiling height of 8 feet (2.44 m). The recommended capacity is usually sufficient for normal heating needs. Please note that the insulation quality of walls and windows are some of the factors that influence heat losses, which modify the required capacity to heat a room. If needed, refer to a specialist (industrial and commercial buildings) who will be able to calculate these heat losses and optimize the required capacity or consult the "Online heating calculation" section of the Stelpro Design Web site (residential buildings).

Do not install the unit where objects or pieces of furniture could be heat damaged.

If the unit capacity is insufficient for the size of the room, it will be in operation continuously, and may become defective earlier and turn yellow.

Respect distances and positions indicated in the installation section.

If the installer or the user modifies the unit, he will be held responsible for any damage resulting from this modification, and the CSA certification could be void.

This unit must not come into contact with a water source and must be protected from splashes (e.g. a wet mop). Do not use it if any part has been immersed. Moreover, do not turn it on or off when standing in water or if your hands are wet.

When starting up the unit for the first time or after a long period, it is normal that it produces some temporary odours and whitish smoke.

Because this unit is hot when in use, it may pose risks even in normal operation. Therefore, be **careful** and **responsible** when using it. To avoid burns, do not let bare skin touch hot surfaces. The unit must cool down for few minutes since it will stay warm for some time after shut-down.

The maximum overhang distance from the front of the unit is **2 to 4 inches (5 to 10 cm)** (according to the model) when installed as a kick space heater. However, make sure objects or pieces of furniture do not come into contact with the unit and keep them at least **6 inches (15.2 cm)** from the unit. Failure to comply with this warning could lead to a fire. Some materials are more heat-sensitive than others, so make sure those near the unit can withstand heat.

Never block unit air vents. This obstruction could lead to overheating, which could result in a fire.

Do not insert or allow foreign objects to enter any air vent as this may cause electric shocks, fires, or damages to the unit.

This unit has hot and arcing or sparking parts inside. It is not designed to be used or stored in wet areas or areas containing flammable liquids, combustible materials or corrosive, abrasive, chemical, explosive and flammable substances such as, but not limited to, gasoline, paint, chlorine, sawdust and cleaning products.

Some areas are dustier than others. Thus, it is the user's responsibility to evaluate if the unit **must be cleaned** based on the amount of dirt accumulated on and inside air vents. Accumulated dirt can lead to a component malfunction or discoloration (yellow). It may cause a fire hazard if not installed and maintained in accordance with these instructions.

The thermal protection activation indicates that the unit has been subjected to abnormal operating conditions. If the thermal protection remains activated or activates and deactivates repeatedly, it is recommended that a qualified electrician or a certified repair centre examine the unit in order to make sure it is not damaged. (Refer to the limited warranty)

If the unit is damaged or defective, cut off power supply at circuit breaker and call a certified repair centre. (Refer to the limited warranty)

TECHNICAL DRAWINGS

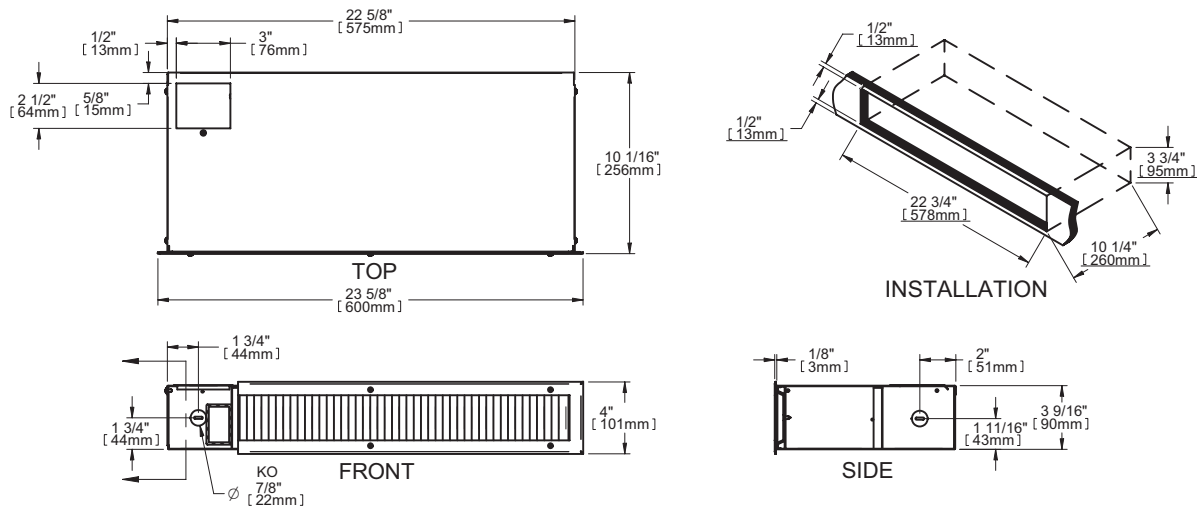

SPECIFICATIONS

KICK SPACE HEATER / CH SERIES	
VOLTS	120, 208, 240 V
WATTS	500 to 1000 W
WEIGHT	13 lb / 5.9 kg
WIDTH	22 5/8" / 575 mm
HEIGHT	4" / 102 mm
DEPTH	9 15/16" / 252 mm

INSTALLATION

Cut off power supply at circuit breaker/fuse before proceeding to the installation.

N.B. This product must be connected by a certified electrician, according to the electrical and building codes effective in your region

1. Cut the required opening according to the dimensions shown hereof.
2. Make the required electrical connections. Make sure to properly ground the unit.
3. Recess the unit into the cut opening.
4. Secure the unit using the two flanged shoulders.
5. Install the grille and the frame.

N.B. This unit may be controlled by using either a wall thermostat or a built-in thermostat (not included).

MAINTENANCE

N.B. In order for the warranty to be valid, the unit must be cleaned regularly.

Cut off power supply at circuit breaker/fuse before cleaning this heater. Use a soft rag for dusting. When cleaning, use only a damp rag and non-abrasive dish soap. Do not use abrasive or chemical cleaners because they may damage the finishing. If the unit is used in a very dusty location, use a vacuum brush to remove dust and other foreign objects from the grilles. Note that cigarette smoke could yellow the discharge grille and that the best way to prevent it is to clean the unit on a regular basis.

Do not use cleaning products identified with these symbols:   

N.B. Note that there is electrical current linked to the unit even if the thermostat is set off. This means that there is a risk of electric shock as long as the unit is energized.

TROUBLESHOOTING

PROBLEM	DEFECTIVE PART OR PART TO CHECK
The unit does not work	- Defective thermostat or wrong thermostat setting - Open circuit breaker or fuse - The thermal protection has been activated - Faulty connections
The unit runs continuously	- Defective thermostat or wrong thermostat setting - Heat losses higher than the unit capacity
The enclosure is extremely hot	- Defective thermal protection - Blocked air vents
The unit cycles under control of the thermal protection (overheat indicator)	- Blocked air vents - Defective motor
Overheating	- Defective thermostat or wrong thermostat setting - Defective motor
The breaker trips when the heater is turned on	- Faulty connections - Voltage higher than that written on the nameplate
The desired room temperature cannot be reached	- One or more elements are defective - Defective thermostat or wrong thermostat setting - Voltage lower than that written on the nameplate - Heat losses higher than the unit capacity

N.B. If you do not solve the problem after checking these points, cut off the power supply at the main electrical panel and contact our customer service (see the "Limited warranty" section to obtain the phone numbers).

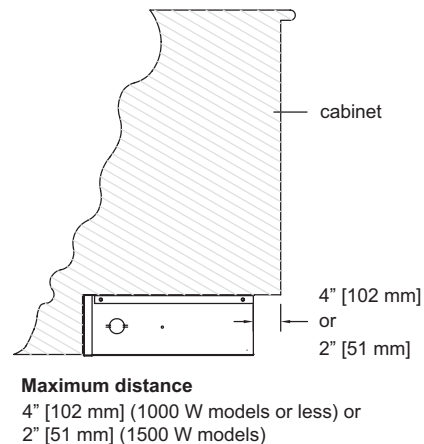
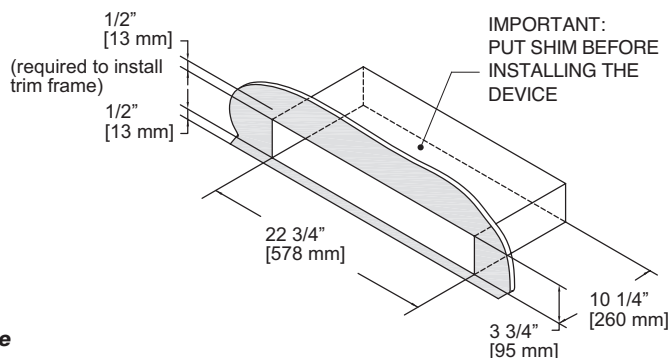

REPLACEMENT COMPONENT LIST

# REF.	# PART	DESCRIPTION
1	BLA-002	BLADE 5" 27' 4B
2	BOUT-250*	THERMOSTAT KNOB (BLACK)
3	ECH050	CLOSED ELEMENT 500 W/80 V
3	ECH125	CLOSED ELEMENT 250 W/120 V
3	ECH150	CLOSED ELEMENT 500 W/120 V
4	M-CH17Z1	FRAME
5	M-CH00C1	GRILLE
6	MO-001	MOTOR 240 V
6	MO-003	MOTOR 240 V
6	MO-011	MOTOR 208 V
6	MO-012	MOTOR 120 V
7	PROT-005	THERMAL PROTECTION L-175
7	PROT-006	THERMAL PROTECTION L-150
8	ST-017	THERMOSTAT SP
8	ST-013	THERMOSTAT DP (600 V MAX)
9	PL-120	PILOT LIGHT 120 V
9	PI-240	PILOT LIGHT 240 V

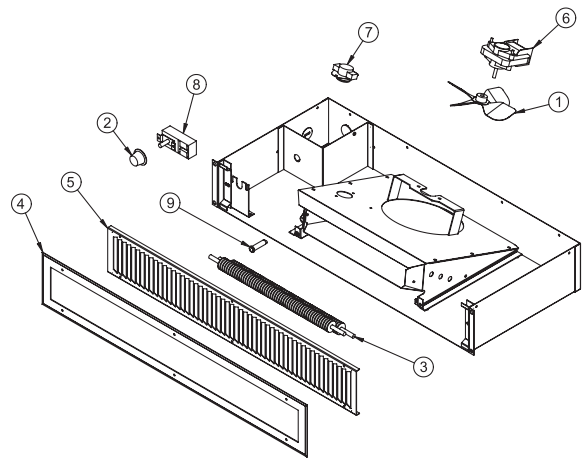

* For built-in single-pole thermostat only (CHT1)

Limited warranty

This limited warranty is offered by Stelpro Design Inc. ("Stelpro") and applies to the following product made by Stelpro: model CH. **Please read this limited warranty carefully.** Subject to the terms of this warranty, Stelpro warrants its products and their components against defects in workmanship and/or materials for the following periods from the date of purchase: **1 year**. This warranty applies only to the original purchaser; it is non-transferable and cannot be extended.

Claim procedure

If at any time during the warranty period the unit becomes defective, you must cut off the power supply at the main electrical panel and contact 1) your installer or distributor, 2) your service center or 3) Stelpro customer service department. In all cases, you must have a **copy of the invoice** and provide the **information written on the product nameplate**. Stelpro reserves the right to examine or to ask one of its representatives to examine the product itself or any part of it before honoring the warranty. Stelpro reserves the right to replace the entire unit, refund its purchase price or repair a defective part. Please note that repairs made within the warranty period must be authorized in advance in writing by Stelpro and carried out by persons authorized by Stelpro.

Before returning a product to Stelpro, you must have a Stelpro authorization number (RMA). To obtain it, call the customer service department at: **1 800 363-3414** (electricians and distributors - French), **1 800 343-1022** (electricians and distributors - English), or **1 866 766-6020** (consumers). The authorization number must be clearly written on the parcel or it will be refused.

Conditions, exclusions and disclaimer of liability

This warranty is exclusive and in lieu of all other representations and warranties (except of title), expressed or implied, and Stelpro expressly disclaims and excludes any implied warranty of merchantability or implied warranty of fitness for a particular purpose.

Stelpro liability with respect to products is limited as provided above. Stelpro shall not be subject to any other obligations or liabilities whatsoever, whether based on contract, tort or other theories of law, with respect to goods or services furnished by it, or any undertakings, acts or omissions relating thereto. Without limiting the generality of the foregoing, Stelpro expressly disclaims any liability for property or personal injury damages, penalties, special or punitive damages, damages for lost profits, loss of use of equipment, cost of capital, cost of substitute products, facilities or services, shutdowns, slowdowns, or for other types of economic loss or for claims of a dealer customer or any third party for such damages. Stelpro specifically disclaims all consequential, incidental and contingent damages whatsoever.

This warranty does not cover any damages or failures resulting from: 1) a faulty installation or improper storage; 2) an abusive or abnormal use, lack of maintenance, improper maintenance (other than that prescribed by Stelpro) or a use other than that for which the unit was designed; 3) a natural disaster or an event out of the control of Stelpro, including, but not limited to, hurricanes, tornadoes, earthquakes, terrorist attacks, wars, overvoltage, flooding, water damages, etc. This warranty does not cover any accidental or intentional losses or damages nor does it cover damages caused by negligence of the user or owner of the product. Moreover, it does not cover the cost of disconnection, transport, and installation.

The warranty is limited to the repair or the replacement of the unit or the refund of its purchase price, **at the discretion of Stelpro**. Any parts replaced or repaired within the warranty period with the written authorization of Stelpro will be warranted for the remainder of the original warranty period. This warranty will be considered null and void and Stelpro will have the right to refuse any claims if **products have been altered** without the written authorization of Stelpro and if the nameplate numbers have been removed or modified. This warranty does not cover scratches, dents, corrosion or discoloration caused by excessive heat, chemical cleaning products and abrasive agents. It does not cover any damage that occurred during the shipping.

Some states and provinces do not allow the exclusion or limitation of incidental or consequential damages and some of them do not allow limitations on how long an implied warranty lasts, so these exclusions or limitations may not apply to you. This warranty gives you specific legal rights and you may have other rights which vary from state to state or from province to province.



This unit complies with the CSA and UL standards

Stelpro Design inc.
Saint-Bruno-de-Montarville (Quebec) J3V 6L7