



# MIRAGE™

## OWNER'S MANUAL

MIR...  
MIR...WC  
MIR...P

**MIR** CONVECTOR



INS-MIR\_EN\_0423

THANK YOU FOR YOUR PURCHASE!  
QUESTION? PROBLEM? CONTACT STELPRO CUSTOMER SERVICE.

**WWW.STELPRO.COM**  
**CONTACT@STELPRO.COM**  
**1-844-STELPRO**

# IMPORTANT INSTRUCTIONS

Before installing or using this product, you must read and understand these instructions and save them for future reference. The manufacturer will not be held responsible for anything, and the warranty will be void if the installer and user do not follow these instructions.

This product must be installed by a qualified person and connected by a **certified electrician** in accordance with local electrical and building codes.

Failure to follow these instructions could result in personal injury, property damage, serious injury and potentially fatal electrical shock.

Protect the unit with the appropriate circuit breakers or fuses according to the nameplate.

Make sure that the supply voltage (volts) corresponds to that indicated on the nameplate.

**This unit must be grounded. Use copper conductors only.**

Use power leads suitable for 75°C (167°F).

Switch off the power supply to the unit at the circuit breaker/fuse before installation, repair and cleaning.

Ensure that the unit is designed for the intended use (if necessary, consult the product catalog or a representative).

**Recommended heating capacity: 1.25 W/cubic foot (0.03 m³).**

This corresponds to **10 W/square foot (0.09 m²)** based on a standard ceiling height of **8 feet (2.44 m)**. The recommended capacity is usually sufficient for normal heating needs. Please note that wall and window insulation quality affects heat loss and impacts the power required to heat a room. If necessary, refer to a specialist who can calculate these heat losses and optimize the required capacity or consult the "Online heating calculation" section of the Stelpro Design website (residential buildings). To heat and increase the comfort of a large room, install several units instead of just one. For example, 2 x 1000 W instead of 1 x 2000 W. If the power of the unit is insufficient for the size of the room, it will run continuously, causing it to age prematurely or turn yellow.

Do not install the unit where objects could be heat damaged. **Respect distances and positions indicated** in the installation section of this guide.

If the installer or user modifies the unit in any way, they will be held responsible for any damage resulting from such modification, and the CSA certification may be voided. This unit must not come into contact with any water source and must be protected from splashes (e.g., water from a mop). Do not use it if any part has been submerged. Moreover, do not turn it on or off when your feet are in water or your hands are wet.

When cutting or drilling a wall to install the unit, make sure not to damage the wiring and other hidden utilities.

When the unit is first turned on or turned on after a long period of time, it's normal for it to temporarily emit some odours and a thin whitish smoke.

Because it heats up, this unit presents risks even when it is operating normally. Therefore, **use caution, good judgment and care** when using it. To avoid burns, do not allow bare skin to come into contact with hot surfaces. Allow the unit to cool down for a few minutes before handling it (it will remain hot for some time).

Leave at least **6 inches (15.2 cm)** of free space between the unit and adjacent surfaces and at least **4 inches (10.2 cm)** from the floor. However, do not allow objects or furniture such as, but not limited to, blankets, towels, bedding, laundry baskets, clothing, papers, etc., to come into contact with the unit and keep them at least **12 inches (30.5 cm)** away from the unit. Moreover, some materials are more heat-sensitive than others, so make sure that those near your appliance can withstand the heat it gives off. Do not install the unit on a wall behind a door. Never block the unit's air inlets and outlets. Doing so will lead to overheating, which may cause a fire. Do not insert foreign objects into the unit's air inlets and outlets, as this may damage the unit and cause electric shock or fire.

The unit contains hot and potentially arcing (sparking) parts. It is not intended for use or storage in damp locations or locations containing flammable liquids, combustible materials, and corrosive, abrasive, chemical or explosive materials such as, but not limited to, paint, gasoline, chlorine, sawdust, and cleaning products.

Some areas are dustier than others. The user must therefore assess whether **the unit needs to be cleaned** based on the amount of dirt accumulated on the air inlets and outlets and inside the unit. Accumulated dirt can cause the unit to turn yellow or cause a component to fail. Failure to install and maintain the unit in accordance with these instructions poses a fire hazard. Activation of the thermal protection indicates that the unit has been subjected to abnormal operating conditions. If the thermal protection remains activated or repeatedly activates and deactivates, the unit should be inspected by a qualified electrician or a recognized repair centre to ensure that it is not damaged (refer to the limited warranty terms beforehand).

If the unit is damaged or defective, turn off the power supply at the circuit breaker/fuse and have it repaired at an authorized service centre (refer to the limited warranty terms beforehand).

## SAVE THESE INSTRUCTIONS

### TROUBLESHOOTING

The following table lists the most common problems and alerts you may encounter with your convector. If your problem isn't listed in the table below or the proposed solution does not solve the problem, turn off the power and contact our customer service team

WWW.STELPRO.COM  
CONTACT@STELPRO.COM  
1-844-STELPRO

PROBLEM/ALERT	POSSIBLE CAUSES AND SOLUTIONS
The unit doesn't start up	<ul style="list-style-type: none"> <li>• Open circuit breaker or fuse</li> <li>• Thermal protection activated</li> <li>• Incorrect connection</li> </ul>
The unit runs continuously	<ul style="list-style-type: none"> <li>• Faulty or incorrectly adjusted thermostat/timer</li> </ul>
The housing is extremely hot	<ul style="list-style-type: none"> <li>• Faulty thermal protection</li> <li>• Blocked air inlet and/or outlet</li> </ul>
The desired room temperature cannot be reached	<ul style="list-style-type: none"> <li>• One or more components are defective</li> <li>• Faulty or incorrectly adjusted thermostat/timer</li> <li>• Voltage lower than that indicated on the nameplate</li> <li>• Heat losses in the room greater than the unit's capacity</li> </ul>
The unit cycles on thermal protection (unit overheating)	<ul style="list-style-type: none"> <li>• Blocked air inlet and/or outlet</li> </ul>
The circuit breaker trips when the unit is switched on	<ul style="list-style-type: none"> <li>• Incorrect connection</li> <li>• Voltage higher than that indicated on the nameplate</li> </ul>
The unit does not heat up	<ul style="list-style-type: none"> <li>• One or more defective components</li> </ul>

# INSTALLING THE CONVECTOR

TO ENSURE A SAFE AND EASY INSTALLATION, TAKE A FEW MINUTES TO READ THIS INSTALLATION GUIDE.

## WHAT'S IN THE BOX THE BOX



Convector

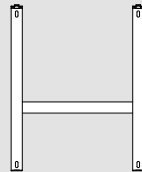

Wall bracket

Twist-on wire connectors\* models:  
MIR..., MIR...WC

\*Not supplied with MIR1501P



## TOOLS AND MATERIALS

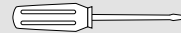

⊖ Flat screwdriver



⊕ Phillips screwdriver

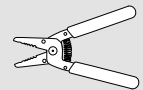

Wire stripper



Stud finder



Level



Tape measure

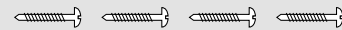

Four to six #6 to #10 round-head wood screws and suitable anchors to secure the convector (see weight on package) to the type of wall

**WARNING:** This convector must be installed by a certified electrician according to the electrical and building codes effective in your region.

## 1

### WHERE TO INSTALL YOUR CONVECTOR

**ATTENTION:** To avoid the risk of overheating and fire, leave a clearance of at least 12 in. (30.5 cm) in front of the convector, 6 in. (15.2 cm) on each side and 4 in. (10.2 cm) of space from the floor.

Do not allow objects or furniture such as, but not limited to, blankets, towels, laundry baskets, clothing, papers, etc., to come into contact with the convector and keep them at least 12 inches (30 cm) away.

The unit is not intended for use or storage in locations that are wet or contain flammable liquids, combustible materials, and corrosive, abrasive, chemical or explosive materials such as, but not limited to, paint, gasoline, chlorine, sawdust, and cleaning products.

No electrical outlets may be located within the housing's enclosure, as interference may occur.

The MIR1501P must be installed within 1.8 m (6 ft) of a 120 V outlet with a dedicated circuit to plug it in.

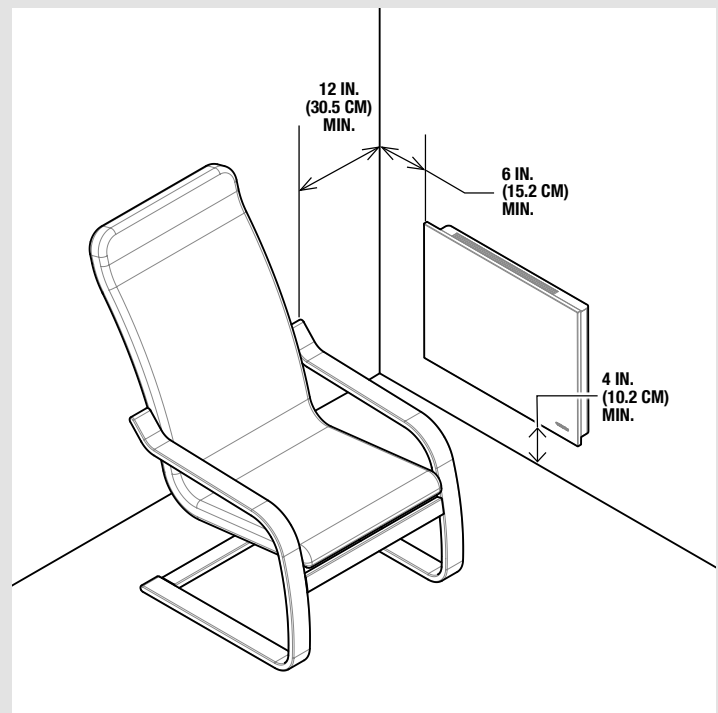

## 2

### TURN OFF THE POWER SUPPLY

To protect yourself from the risk of electric shock, turn off the power to the power cables at the electrical panel.

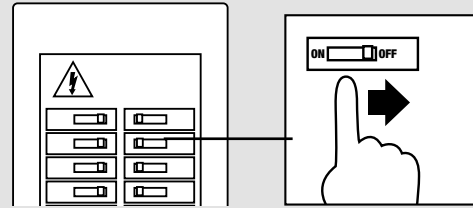

## 3

### REMOVE THE WALL BRACKET FROM THE UNIT

1. Lay the unit flat on a clean, non-abrasive surface to avoid damaging the front of the unit.
2. Press down on each spring with a screwdriver.
3. Swivel the bracket upwards.
4. Remove the bottom hooks from the unit.

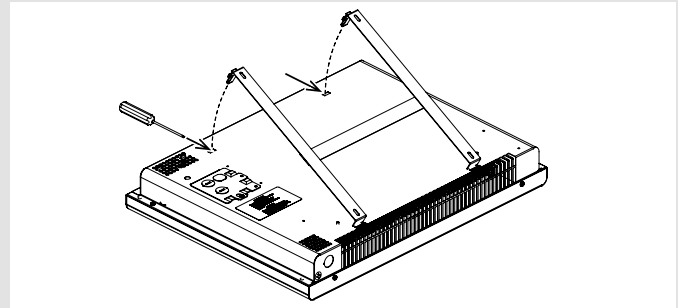

## 4

### PREPARING THE SURFACE FOR INSTALLATION

**NOTE: The wall where you install the unit must be as flat as possible to ensure a secure and sturdy connection between the unit and the bracket. It is very important to follow this guideline to avoid damaging the bracket during installation. This could cause the locking system to malfunction.**

1. Using the stud finder, locate studs and other structures that may be inside the wall.
2. To determine where to install the unit on the wall, use the wall bracket as a guide. For a sturdier installation, align one side of the wall bracket with a stud as shown in the illustration.
3. To install the unit at the minimum height of 4 in. (10.2 cm), place the bracket on the floor on the wall where the unit will be installed and draw a temporary line under its horizontal cross bar with a pencil. **[A]**
4. Align the bottom of the wall bracket with the temporary line drawn in the previous step or at the desired height. Make sure the bracket is level. **[B]**

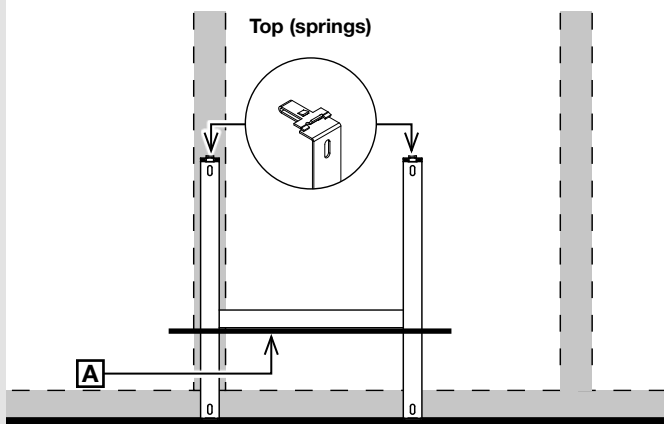

5. Mark the position of the screws in the bracket's slots **[C]**. Make sure it is level.
6. Install the appropriate anchors to secure the convector (see weight on the packaging) according to the type of wall, then screw\* the bracket in place.
7. Pull the power cable out of the wall. Allow extra cable to easily connect the unit's wires.

**\*Note: When drilling the wall, be careful not to damage electrical wiring and other hidden utilities.**

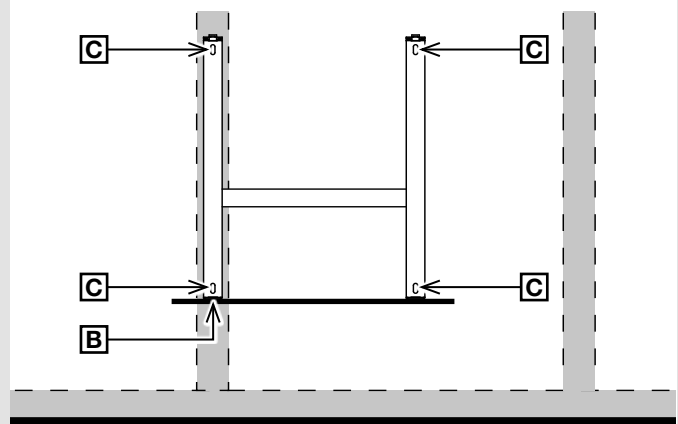

# 5

## CONNECTING THE WIRING

**WARNING: Use only copper wire that can withstand a temperature of 75°C (167°F).**

1. Unscrew and remove the junction box door and set it aside.
2. Pull the wires out of it.
3. If necessary, strip the wires from the power cable **[A]** using a wire stripper.
4. Connect the bare wire (ground) to the green wire **[B]** using one of the supplied twist-on connectors **[C]** (see connection diagram).
5. Then connect the convector **[D]** and power supply wires in the same way with the two other twist-on connectors. Tighten them on the wires to ensure each connection is secure.
6. Then place all the wires in the junction box, taking care to place the cable in one of the clearances provided **[E]**.

**NOTE:** If installing in a knockout **[F]**, use a wire clamp to secure the power cable. Replace the junction box cover and insert the screw to hold it in place.

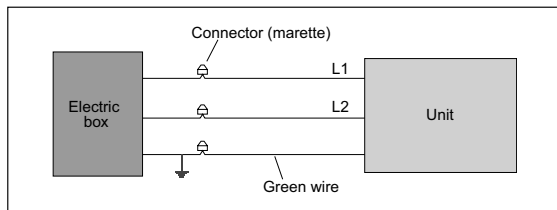

**ELECTRICAL DIAGRAM OF THE DEVICE**

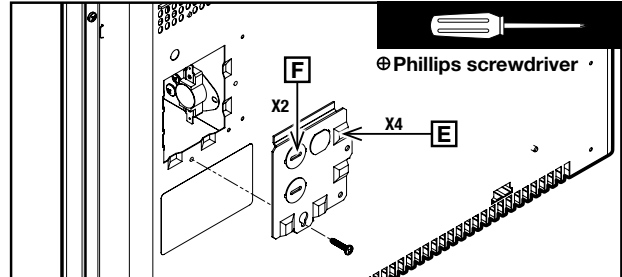

**REMOVING THE JUNCTION BOX COVER**

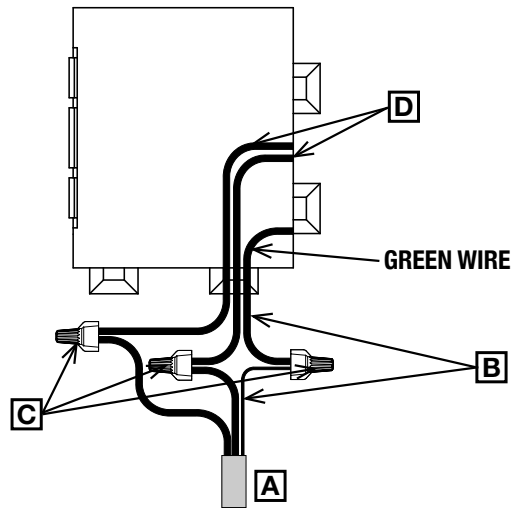

**CONNECTION DIAGRAM**

### CONNECTING THE MIR1501P MODEL (WITH CORD)

This model is equipped with a three-pin plug:

- For safety reasons, the plug can only be inserted into a grounded outlet. If you are unable to insert the plug into the outlet, contact your electrician. Do not override the safety grounding feature of the plug.
- The convector must be plugged into a dedicated 120V circuit. Adding other units to this circuit may cause the circuit breaker to trip.
- Plug the unit's cord directly into a wall outlet (do not use an extension cord).

**WARNING: No electrical outlets may be located within the housing's enclosure, as interference may occur.**

# 6

## HANG THE UNIT ON THE WALL BRACKET

**CAUTION:** Ensure that the convector is correctly engaged in the wall bracket to avoid dropping and damage.

1. Insert the unit into the lower hooks [A] of the wall bracket.

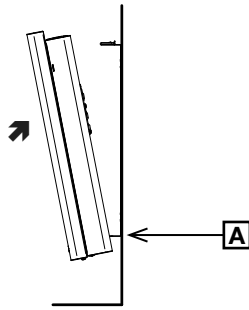

2. Tilt the top of the unit and snap it into the top hooks.

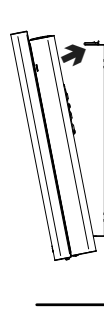

3. Push the unit to ensure it is firmly seated. [B]

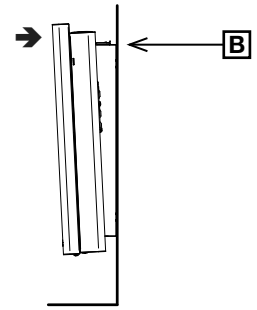

# 7

## TURNING THE POWER BACK ON

1. Restore power back to the convector. Make sure that the unit works by raising the temperature until it starts to heat.
2. See the **Using the convector** section to get the most out of your unit.

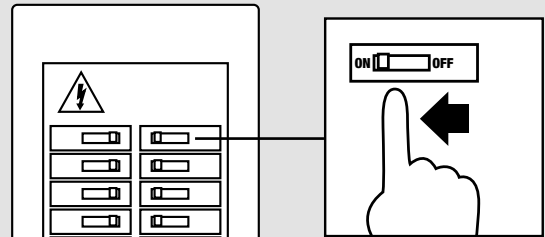

# USING THE CONVECTOR

**WARNING:** Before using your convector, make sure that it has been installed by a certified electrician in accordance with the electrical and building codes in effect in your area. Before using the unit, make sure both the air inlet (bottom) and air outlet (front) are not obstructed.

## CONVECTOR CONTROL

Depending on the model you've chosen, refer to the table below for information on how to control the convector.

MIR..., MIR1501P	These models are controlled using a <b>built-in thermostat</b> to adjust the room temperature setpoint (see page 7 for details).	
MIR...WC	This model is controlled by a <b>wall-mounted thermostat</b> to adjust the room temperature setpoint.	---

# CONTROL WITH A BUILT-IN ELECTRONIC THERMOSTAT

## TEMPERATURE CONTROL AND DISPLAY

The thermostat has two modes: the DAY mode, identified on the digital screen by a (☀️) icon and the NIGHT mode, identified by a (🌙) icon. To switch from one mode to the other, simultaneously press down both buttons once.

**NOTE: When you select the NIGHT mode, the thermostat will respond accordingly for the duration of the time preprogrammed for this mode (see “Selection of the Duration of the NIGHT Mode”). When the preprogrammed time has passed, the thermostat will automatically return to the DAY mode.**

## ☀️ DAY MODE

### HOW TO SET THE DAY TEMPERATURE

By pressing down the top or bottom button, you will enter the setting mode indicated by the flashing SUN icon. This way, you can see the DAY temperature setting.

You can change the temperature with these same buttons by increasing (top button) or decreasing (bottom button) the set point. The temperature set point will increase or decrease by increments of 0.5 °C (or 1 °F) each time you press down a button. If you hold down the button, the temperature will quickly scroll through, allowing a faster and more efficient setting.

Once the temperature is set, release the button; normal display will resume after three (3) seconds.

### NIGHT LIGHT MODE

Normally, the backlight is activated when you press down the button, and stays on for fifteen (15) seconds afterwards. To keep the backlight on, simultaneously press down both buttons for 3 seconds (until the backlight blinks), then release. Repeat this procedure to deactivate the night light mode.

### SELECTION OF THE TEMPERATURE SCALE

To change the temperature scale (°C or °F), simultaneously press down both buttons for eight (8) seconds, the °C or °F symbol will blink. Release the buttons to set the new scale (note that the backlight will blink after 3 seconds).

## 🔒 LOCK OPTION

It is possible to impose a maximum temperature set point by activating this mode. Then, it becomes impossible to exceed this set point, regardless of the current mode (DAY/NIGHT). However, it is still possible to lower the temperature at your discretion. All the other functions remain unchanged. For increased security, the power supply needs to be cut off in order to deactivate the lock.

### LOCKING PROCEDURE

1. From the DAY mode, adjust the set point to the maximum desired value.
2. Simultaneously press down both buttons for more than 13 seconds, until the LOCK icon is displayed (note that the backlight will blink after 3 seconds and the °C and °F symbols, after 8 seconds).
3. Release the buttons. The thermostat is now locked.

### UNLOCKING PROCEDURE

1. Cut off the power supply of the thermostat at the electrical panel.
2. Wait about 1 minute.
3. Restore the power supply of the thermostat at the electrical panel.
4. The LOCK icon blinks on the thermostat display, meaning that it is possible to unlock the thermostat.
5. While the LOCK icon is blinking, simultaneously press down both buttons for more than 10 seconds, until the LOCK icon disappears.
6. Release the arrows. The thermostat is now unlocked.

**NOTE: If the thermostat is not unlocked within 5 minutes after restoring the power supply, the 🔒 icon will stop blinking and it will be impossible to unlock the thermostat without cutting off the power supply again.**

## 🌙 NIGHT MODE

### HOW TO SET THE NIGHT TEMPERATURE

By pressing down the top or bottom button, you will enter the setting mode indicated by the flashing MOON icon. This way, you can see the NIGHT temperature setting.

You can change the temperature with these same buttons by increasing (HIGH button) or decreasing (LOW button) the set point. The temperature set point will increase or decrease by increments of 0.5 °C (or 1 °F) each time you press a button. If you hold down the button, the temperature will quickly scroll through, allowing a faster and more efficient setting.

Once the temperature is set, release the button; normal display will resume after three (3) seconds.

### SELECTION OF THE DURATION OF THE NIGHT MODE

By simultaneously pressing down both buttons for three (3) seconds, you will be able to program the desired duration of the NIGHT mode. You can decrease or increase the number of hours (1 to 999 hours). If you hold down the button, the hours will quickly scroll through allowing a faster setting. Normal display will resume three (3) seconds after releasing the button.

Therefore, you can regulate the unit according to your specific needs. For example, to save energy and increase comfort at night, you can set the number of hours so that the unit automatically switches to DAY mode when you awake (see “Automatic Mode”). Furthermore, if you are going away for some time and wish to save energy during your absence without having to come back to an uncomfortable room, simply indicate the number of hours you will be absent (1 day = 24 hours, 1 week = 168 hours). By setting the NIGHT mode this way before leaving, the temperature will automatically switch back to DAY mode upon your return, thus ensuring optimal comfort.

## 🔄 AUTOMATIC MODE

To activate or deactivate this mode, you must switch to the “Selection of the Duration of the NIGHT Mode”. The number of programmed hours must be 23 or less to activate the AUTOMATIC mode. To activate it, simultaneously press down both buttons for three (3) seconds. To deactivate this mode, simultaneously press down both buttons again for three (3) seconds. If the number of programmed hours is increased to more than 23, the AUTOMATIC mode will immediately be deactivated (if it was activated). The AUTOMATIC mode icon lights on or off as applicable.

If you do not press down any button for five (5) seconds, you exit the programming mode and return to the NIGHT mode, the programming of the NIGHT mode is re-initialized and the AUTOMATIC mode becomes effective (if it was activated). After 24 hours, the thermostat returns to the NIGHT mode automatically.

Then, the night programming is re-initialized and another 24 hours cycle starts. Even if the thermostat is in AUTOMATIC mode, you can switch from DAY mode to NIGHT mode at your discretion, it will not impact the 24 hours cycle or the automatic return of the NIGHT mode.

**NOTE: Activation of the OFF mode deactivates the AUTOMATIC mode.**

When power is restored (after a power failure for example), the AUTOMATIC mode is deactivated. If it was activated before the power-down, the AUTOMATIC mode icon blinks. Then, the thermostat will be in DAY mode. The blinking will cease as soon as you press down a button.

## ❄️ ANTIFREEZE PROTECTION

In order to protect your home against freezing and limit energy consumption during long absences, put the thermostat on ANTIFREEZE mode. To enter this mode, lower the day temperature to between 3°C and 5°C. A snowflake icon (❄️) is displayed. This icon indicates that the economic and secure ANTIFREEZE mode is on.

## THE “NO HEAT” MODE

To turn the heat off, you must lower the day temperature to less than 3°C. The inscription “OFF” is displayed (note that there is still electrical current to the unit, meaning that there is a risk of electrical shock).

# MAINTAINING THE CONVECTOR

**NOTE:** For the warranty to be valid, the fan heater's air inlet and outlet must be cleaned regularly. Over time, cigarette smoke may cause the outlet grill to yellow. The best way to prevent yellowing is to clean the unit regularly.

**WARNING:** The unit is powered even if the thermostat is in the off position. You could therefore receive an electric shock as long as the unit is powered. Switch off the power supply at the circuit breaker/fuse before cleaning the unit.

Remove dust from the unit with a soft cloth. Clean only with a damp cloth. Do not use any cleaning products to avoid yellowing of the unit. Do not use chemical or abrasive cleaning agents, as they may damage the unit's coating. If the unit is in a very dusty place, use the dusting brush of a vacuum cleaner to remove dust and other foreign objects from the unit.

#### NEVER USE:

- Chlorine
- A metal brush or scouring pad
- Cleaning products that contain abrasives
- Cleaning products that bear the following symbols:



# STELPRO LIMITED WARRANTY

This limited warranty is offered by STELPRO DESIGN Inc. ("STELPRO") for the following STELPRO manufactured product and model: **MIR**. Please read this limited warranty carefully. Subject to the terms of this warranty, STELPRO warrants its products and their components against defects in material and workmanship for the following periods from the date of purchase: **5 years (3 years on electronic components)**. This warranty applies to the original purchaser only; it is not transferable and cannot be prolonged or extended.

#### CLAIM PROCEDURE

If at any time during the warranty period the unit becomes defective, you must cut off the power supply at the main electrical panel and contact 1) your installer or distributor, 2) your service center or 3) STELPRO's customer service department, who will advise you on the procedure to follow. In all cases, you must have a **copy of the invoice** and provide the **information listed on the product nameplate**. STELPRO reserves the right to inspect or have inspected any product or part before honouring a claim. STELPRO also reserves the right to replace the unit, refund the purchase price, or repair or have repaired a defective part. Please note that repairs made within the warranty period must be authorized in advance in writing by STELPRO and carried out by a person authorized by STELPRO.

Before returning a product to the STELPRO plant, you must have a Stelpro authorization number (RMA). To obtain it, call the customer service department at: **1-844-STELPRO**. The authorization number must be clearly written on the parcel or it will be refused.

#### CONDITIONS, EXCLUSIONS AND DISCLAIMERS

This warranty is exclusive and in lieu of all other representations and warranties (except of title), expressed or implied, and Stelpro expressly disclaims and excludes any implied warranty of merchantability or implied warranty of fitness for a particular purpose.

Stelpro's liability is limited to what is provided in this warranty. Stelpro shall not be subject to any other obligation or liability whatsoever, whether based on contract, tort or other theories of law, with respect to goods or services furnished by it, or any undertakings, acts or omissions relating thereto. Without limiting the generality of the foregoing, Stelpro expressly disclaims any liability for property damage or personal injury; penalties; special or punitive damages; loss of profits or use; cost of capital; cost of replacement products, facilities or services; shutdowns; downtime; and any other type of pecuniary loss. Stelpro also declines

any responsibility for claims from customers or any other third party for such damages. Furthermore, Stelpro refuses to take responsibility for any indirect, incidental and possible damage of any kind.

This warranty does not cover damage or breakage resulting from 1) improper installation or storage; 2) misuse, abuse, misapplication, lack of maintenance, improper servicing (other than that intended by STELPRO) or use other than that for which the product was designed; 3) an act of God or an event beyond STELPRO's control, including, but not limited to, hurricane, tornado, earthquake, terrorist attack, war, power surge, flood, water damage, etc. This warranty does not cover any accidental or intentional losses or damages, nor does it cover damages caused by negligence of the user or owner of the product. Moreover, it does not cover the cost of disconnection, transport, and installation.

This warranty is limited to the repair of the unit, its replacement or the reimbursement of its purchase price **at the discretion of STELPRO**. Parts that are replaced or repaired with STELPRO's written authorization within the warranty period will themselves be warranted for the remaining warranty period of the original part. This warranty will not be valid and STELPRO may deny any claim if the unit has been **modified in any way** without STELPRO's prior written authorization or if the numbers displayed on the nameplate have been removed or altered. This warranty does not cover scratches, dents, corrosion or discoloration caused by excessive heat, chemical cleaning products or abrasive agents. It also does not cover damage or breakage during shipping.

Some states and provinces do not allow the exclusion or limitation of incidental or consequential damages, and some of them do not allow limitations on how long an implied warranty lasts, so these exclusions or limitations may not apply to you. This warranty gives you specific legal rights, and you may have other rights which vary from state to state or from province to province.