



www.stelpro.com

User's guide

“SB” Series / “SB-M” Series Dual energy duct heater

This section must be read carefully by the installer.

(Replacement component list included)

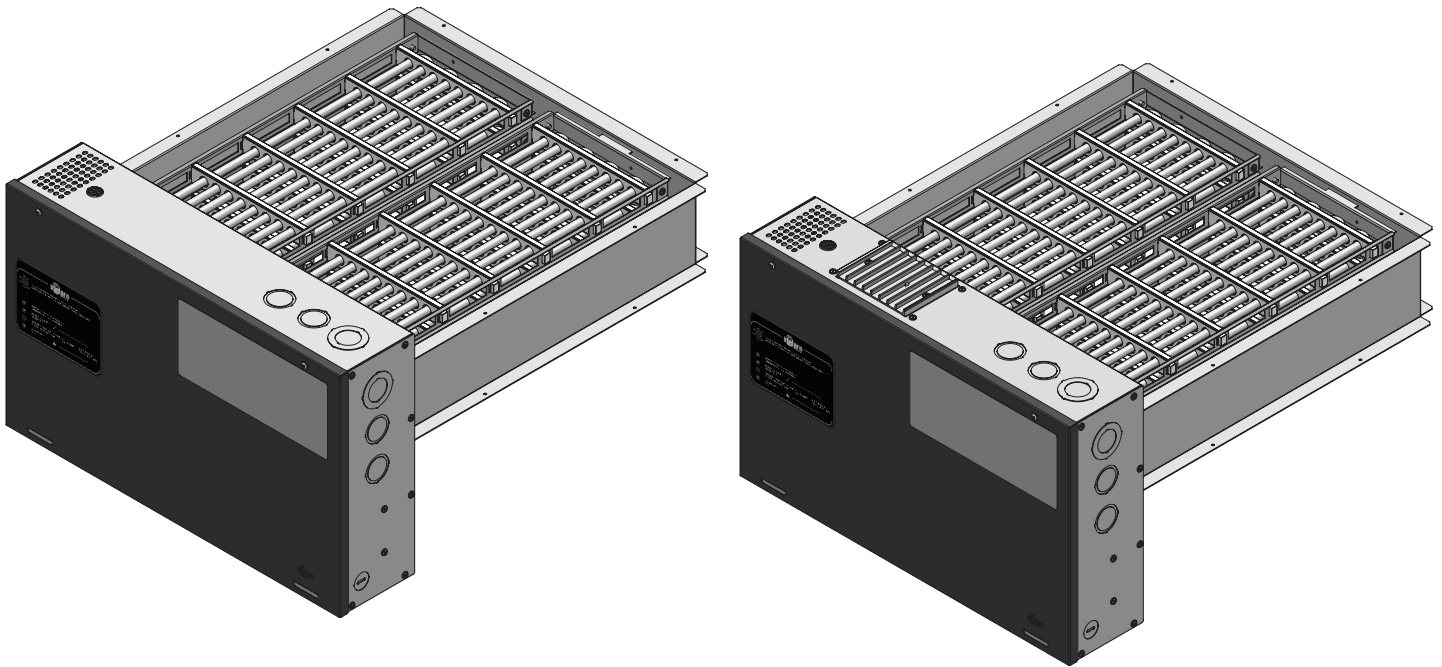

For further information or to consult this guide online, please visit our Web site.

 **WARNING**  **WARNING**  **WARNING**  **WARNING** 

Before installing and operating this product, the user and/or installer must read, understand and follow these instructions and keep them handy for future reference. If these instructions are not followed, the warranty will be considered null and void and the manufacturer deems no further responsibility for this product.

This product must be installed by a qualified person and connected by a **certified electrician**, according to the **electrical and building codes** effective in your region.

The following instructions must be adhered to in order to avoid personal injuries or property damages, serious injuries and potentially fatal electric shocks.

Protect the heating unit with the appropriate circuit breaker or fuse, in accordance with the nameplate.

Make sure the line voltage (volt) is consistent with that indicated on the unit's nameplate.

This unit must be **grounded**.

Switch off the power at the circuit breaker/fuse before installing, repairing and cleaning the unit.

Make sure the unit is appropriate for the intended use (if needed, refer to the product catalog or a representative).

If the unit's capacity is insufficient for the size of the house, it will be in operation continuously, and may become defective earlier.

Respect distances and positions indicated in the installation section.

If the installer or the user modifies the unit, they will be held responsible for any damage resulting from this modification, and the UL certification could be void.

This unit must not come into contact with a water source and must be protected from splashes (e.g. a wet mop). Do not use it if any part has been immersed. Moreover, do not turn it on or off when standing in water or if your hands are wet.

Because this unit is hot when in use, it may pose risks even in normal operation. Therefore, be **careful** and **responsible** when using it. To avoid burns, do not let bare skin touch hot surfaces. Let the unit cool down for a few minutes before handling it (it stays warm for some time after shut-down).

Never block air vents. This obstruction could lead to overheating, which could result in a fire.

Do not insert or allow foreign objects to enter any air vent as this may cause electric shocks, fires, or damages to the unit.

This unit has hot and arcing or sparking parts inside. It is not designed to be used or stored in wet areas or areas containing flammable liquids, combustible materials or corrosive, abrasive, chemical, explosive and flammable substances such as, but not limited to, gasoline, paint, chlorine and cleaning products.

Some areas are dustier than others. Thus, it is the user's responsibility to evaluate if the **filter must be changed** based on it. Accumulated dirt can lead to a component malfunction or discoloration (yellowing). It may cause a fire hazard if not installed and maintained in accordance with these instructions.

Thermal protection activation indicates that the unit has been subjected to abnormal operating conditions. If the thermal protection remains activated or activates and deactivates repeatedly, it is recommended that a qualified electrician or a certified repair centre examine the unit in order to make sure it is not damaged. (Refer to the limited warranty).

If the unit is damaged or defective, cut off power supply at circuit breaker/fuse and call a certified repair centre. (Refer to the limited warranty).

Label all wires prior to disconnection when servicing controls. Wiring errors can cause improper and dangerous operation.

Note:

When a part of the product specification must be changed to improve operability or other functions, priority is given to the product specification itself. In such instances, the instruction manual may not entirely match all the functions of the actual product.

Therefore, the actual product and packaging, as well as the name and illustration, may differ from the manual.

MODELS “SB” OPERATION

Upon a call for heat from the thermostat, the « SB » dual energy duct heater is designed to activate either its own built-in heating assembly or an external heating unit; The decision to activate one or the other is based upon the selected operating mode and/or outdoor temperature. To this end, the heat demand signal is conveyed by the thermostat to the duct heater via terminals “W” and “R” while the SHQ* outdoor sensor will provide the outdoor temperature signal.

*outdoor sensor provided and installed by Hydro-Québec.

A selector switch on the duct heater allows for 3 operating modes: Dual Energy Mode, Electric Mode and Fossil fuel* Mode (or gas). Simply press the selector switch to scroll through the 3 operating modes; accordingly the selected mode will be indicated by means of either the “Fossil fuel” or “Electric” indicator light or both (Dual Energy).

*note: the term fuel refers here to both gas and heating oil.

Dual Energy Mode

In this operating mode the duct heater will decide to activate either its own heating assembly or the furnace heat output in accordance with the outdoor temperature sensor's signal.

More specifically, while the thermostat calls for heat, as the outdoor temperature drops to -12°C or -15°C (depending on the climatic zone in which you live) the outdoor sensor's signal will trigger the duct heater to deactivate its heating assembly and trigger the furnace burner. Conversely, while the thermostat calls for heat, as the outdoor temperature rises to -12°C or -15°C (depending on the climatic zone), the outdoor sensor's signal will trigger the duct heater to deactivate the furnace burner and subsequently, following a 5 minutes delay, trigger simultaneously its heating assembly and the furnace blower.

Note that no electric element will be activated within the five minutes following the operation of the furnace burner.

Electric Mode

In this operating mode, regardless of the outdoor temperature sensor's signal, the duct heater triggers its own heating assembly in response to the thermostat signal.

Fuel Mode (or gas)

In this operating mode, irregardless of the outdoor temperature sensor's signal, the duct heater redirects the thermostat call for heat to the furnace.

Auto-transfer

In the event that a malfunction of the activated mode is detected, the duct heater will systematically override the activated mode and revert to its alternate mode. More specifically, the SB dual energy duct heater control board is equipped with a “duct” temperature-sensor. This device enables the controller to detect a malfunction in the heating system (electric or fuel). When the thermostat sends a demand for heat to the duct heater controller, this will start the heating cycle of one of the two heating modes (electric or fuel) depending on the heating mode selected by the user and/or the condition of the outdoor-temperature sensor's signal. Every time a heating cycles starts whether in electric mode or in fuel mode, a 15 minutes countdown begins.

When the countdown has finished, if the temperature of the duct does not exceed the temperature of the auto-transfer and the thermostats demand for heat is still present, the heating mode activated at the beginning of that cycle will be deactivated and the opposite mode will be activated. For example: When the thermostat sent the demand for heat, the controller activated the electric mode, the auto-transfer will be the fuel mode and vice versa.

At the same time the diagnostic pilot light (red) will start to blink every second indicating the auto-transfer is activated. The green pilot light will also indicate which heating mode is taking over (for example fuel if we were heating in electric mode), as it starts to blink in alternation with the red pilot light the other heating modes green pilot light is off.

Note that if the fuel mode was selected and the burner does not function for lack of fuel for example, in this situation the heating mode will automatically switch to the electric mode, add the five minutes delay during which the elements will not be activated due to the fact that the burner has just finished operating.

While auto-transfer is activated, at any time the user can press the heating mode selector button to reinitialize the auto-transfer and return to the heating mode of his choice.

Auto-transfer will remain active for a 12 hour period after which, the controller will try again to activate the faulty heating mode which initially triggered the auto-transfer. This function is useful if the corrective measure is taken before the auto transfer is re-initialized.

Auto-transfer Temperature

The auto-transfer temperature is defined as being the minimal air temperature of the duct, which starts the auto-transfer (after a 15 minute delay). The installer can adjust this by using the rotary button located on the control board. This is directly accessible by the cover of the electrical compartment without having to disassemble the unit. The rotary button consists of a scale in degrees Celsius and offers an adjustable temperature range between 25°C and 50°C .

The automatic transfer temperature adjustment is a two-fold procedure. The installer must first take a measurement of the duct air temperature while the SB heating elements are full-on and the fuel furnace is not providing any heat output. The installer then sets the rotary dial to a temperature lesser than the duct air temperature measurement. For instance, the installer could set the automatic transfer temp. adjustment to 45°C after taking a duct air temperature measurement of 55°C .

SB SERIES USER INTERFACE

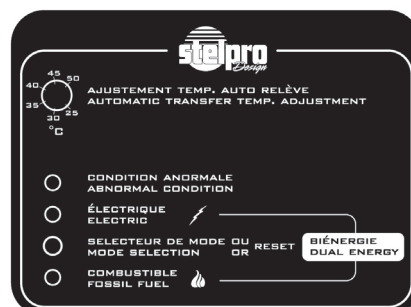

TROUBLESHOOTING SB MODEL

PROBLEM	DEFECTIVE PART OR PART TO CHECK
The unit does not work	<ul style="list-style-type: none">- Defective thermostat, wrong thermostat setting, positioning or wiring- Open circuit breaker or fuse- Faulty power supply connections- Defective transformer
The unit has power but the elements do not work	<ul style="list-style-type: none">- Defective relay- Tripped manual reset thermal cut-out
The unit runs continuously	<ul style="list-style-type: none">- Defective thermostat, wrong thermostat setting, positioning or wiring- Heat losses greater than the heating capacity of the unit
Element operating and/or cycling continuously	<ul style="list-style-type: none">- Defective 24V relay (contact probably welded)
All the element operating and/or cycling when there is a heating demand	<ul style="list-style-type: none">- Defective furnace fan- Obstructed Return and/or supply air
Unit is overheating	<ul style="list-style-type: none">- Defective furnace fan- Obstructed Return and/or supply air
The breaker trips when the heater is turned on	<ul style="list-style-type: none">- Faulty power supply connections- Voltage higher than that indicated on the nameplate
Unable to attain desired room temperature	<ul style="list-style-type: none">- One or more defective elements- Defective thermostat, wrong thermostat setting, positioning or wiring- Voltage lower than that indicated on the nameplate- Heat losses greater than the heating capacity of the unit- Defective 24V relay- Tripped manual reset thermal cut-out
The Red "Diagnostic" pilot light is always on	<ul style="list-style-type: none">- The plenum's temperature-sensor is defective or wrongly connected
The Red "Diagnostic" pilot light blinks every second	<ul style="list-style-type: none">- The Control board has detected a malfunctioning on one of the two Heating modes and has started the auto-transfer process
The Red "Diagnostic" pilot light blinks four times every two seconds and pause for two seconds	<ul style="list-style-type: none">- The plenum's air temperature is above 68 C- Dirty air filter – worn fan belt
The green pilot light "ELECTRIC" blinks every second	<ul style="list-style-type: none">- The furnace burner was operating five minutes prior to a demand for heat in electric mode or there was a power failure within the last five minutes or a problem with the plenum temperature-sensor
The green pilot light "FUEL" blinks every second	<ul style="list-style-type: none">- There was a power failure within the last five minutes or a problem with the plenum temperature-sensor

N.B. If you do not solve the problem after checking these points, cut off the power supply at the main electrical panel and contact our customer service (see the "Limited warranty" section to obtain the phone numbers).

MODELS “SB-M” OPERATION

The SB-M series duct heater modulates the electric element's output according to the set point temperature in the duct. This model was specially developed to augment the heat from a heat pump. However, It is possible to use this unit only, without any other heat source. In any case, the ultimate goal is to obtain a constant air temperature in the duct.

In order to achieve this, the control board reads the duct temperature and compares it to the set point chosen by the installer. The set point is adjusted via a rotating knob accessible on the front of the unit. If the temperature read is below the set point, the electronic control activates the elements until the set point is achieved. If the duct air temperature should pass the set point, the electronic control will deactivate the elements until the set point is achieved.

Three types of operating modes are possible: “ELECTRIC / ELECTRIC + HEAT PUMP”, “FOSSIL FUEL ONLY” and “ELECTRIC + EMERGENCY FOSSIL FUEL”. The button on the control panel selects the heating mode. The modes, “ELECTRIC / ELECTRIC + HEAT PUMP” and “FOSSIL FUEL ONLY” are indicated by a light illuminated next to the text. When both lights are illuminated, the unit is in “ELECTRIC + EMERGENCY FOSSIL FUEL” mode.

OPERATING OPTIONS

Electric / Electric + Heat Pump

When “Electric/ Electric + Heat pump mode” is selected, the duct heater only controls its own heating elements. The duct heater, while the thermostat calls for a heat demand, modulates its heat output to attain the required (duct) temperature. Electric + heat pump: If the heating system incorporates a heat pump, both the heat pump and duct heater are controlled by the thermostat heat demand. The duct heater modulated output complements the heat-pump output to achieve the required (duct) temperature. (When electric/ electric + heat pump mode is selected, the “W” terminal on the duct heater terminal block labelled “heat pump” should be free of any connection).

Fossil Fuel Only

When “Fossil Fuel Only mode” is selected, the duct heater only controls the fossil fuel furnace heat output. To enable the fossil fuel only mode the W14 (stage) jumper must be set on 2.

Emergency Fossil Fuel

The “Emergency fossil fuel control mode” requires a one stage thermostat (W or Y signal) + emergency mode (E signal). This control mode allows the thermostat to use the fossil fuel furnace as a supplemental heat source. To enable the fossil fuel only mode the W14 (stage) jumper must be set on 2. As with the electric/ electric + heat pump mode, the thermostat heat demands are conveyed to the duct heater (and heat pump if so equipped). However, if the duct heater/ heat pump combined heat output is still insufficient the thermostat will redirect the heat demand to the fossil fuel furnace. The emergency fossil fuel mode requires a double stage thermostat for the fossil fuel furnace heat output is to be controlled by means of the thermostat second heating stage.

SB-M SERIES USER INTERFACE

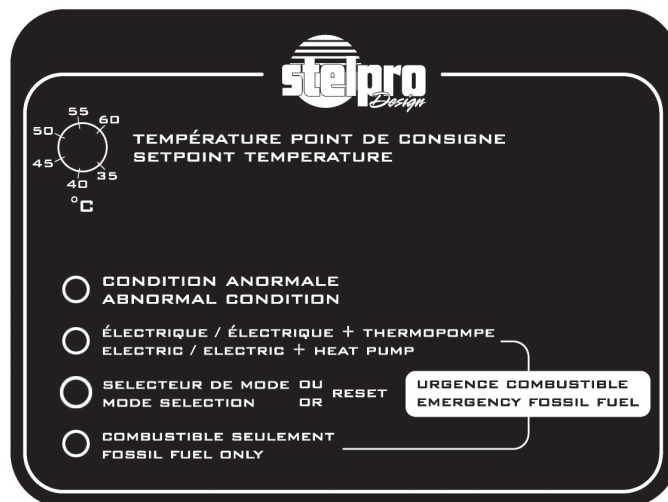

TROUBLESHOOTING SB-M MODEL

PROBLEM	DEFECTIVE PART OR PART TO CHECK
The unit does not work	<ul style="list-style-type: none"> - Defective thermostat, wrong thermostat setting, positioning or wiring - Open circuit breaker or fuse - Faulty power supply connections - Defective transformer
The unit has power but the elements do not work	<ul style="list-style-type: none"> - Defective relay - Tripped manual reset thermal cut-out
The unit runs continuously	<ul style="list-style-type: none"> - Defective thermostat, wrong thermostat setting, positioning or wiring - Heat losses greater than the heating capacity of the unit
Element operating and/or cycling continuously	<ul style="list-style-type: none"> - Defective 24V relay (contact probably welded)
All the element operating and/or cycling when there is a heating demand	<ul style="list-style-type: none"> - Defective furnace fan - Obstructed Return and/or supply air
Unit is overheating	<ul style="list-style-type: none"> - Defective furnace fan - Obstructed Return and/or supply air
The breaker trips when the heater is turned on	<ul style="list-style-type: none"> - Faulty power supply connections - Voltage higher than that indicated on the nameplate
Unable to attain desired room temperature	<ul style="list-style-type: none"> - One or more defective elements - Defective thermostat, wrong thermostat setting, positioning or wiring - Voltage lower than that indicated on the nameplate - Heat losses greater than the heating capacity of the unit - Defective 24V relay - Tripped manual reset thermal cut-out
The Red "DIAGNOSTIC" pilot light is always on	<ul style="list-style-type: none"> - The plenum's temperature-sensor is defective or wrongly connected
The Red "DIAGNOSTIC" pilot light blinks every second n/a when "ELECTRIC" option is selected)	<ul style="list-style-type: none"> - The control board has detected a malfunction in the "fossil fuel" mode. Verify the burner and level of fuel.
The Red "DIAGNOSTIC" pilot light blinks four times every two seconds and pause for two seconds	<ul style="list-style-type: none"> - The plenum's air temperature is above 68°C - Dirty air filter or worn fan belt
The red "DIAGNOSTIC" pilot light blinks six times in 3 seconds and a pause for 3 seconds	<ul style="list-style-type: none"> - The "Y" signal is present along with the "W" signal - Verify the thermostat programming
The red "DIAGNOSTIC" pilot light blinks 8 times in 4 seconds and a pause for 4 seconds	<ul style="list-style-type: none"> - The relay is cycling between proportional mode and stage mode for 12 hours. The W4 jumper should be set to "T" and not to "R"
The red "DIAGNOSTIC" pilot light blinks 10 times in 5 seconds and a pause for 5 seconds	<ul style="list-style-type: none"> - The W1 jumper is set to "B" instead of "M" - There is a signal on the "W" screw thermostat control board terminal
The red "DIAGNOSTIC" pilot light blinks 12 times in 6 seconds and a pause for 6 seconds	<ul style="list-style-type: none"> - The W14 jumper is set to "1" instead of "2" - There is a signal from the second stage on the "W" screw pump control board terminal

N.B. If you do not solve the problem after checking these points, cut off the power supply at the main electrical panel and contact our customer service (see the "Limited warranty" section to obtain the phone numbers).

SAFETY FEATURES (“SB” & “SB-M”)

Les chauffe-air biénergie “SB” et “SB-M” est muni de caractéristiques qui accroissent sa sécurité de fonctionnement. Les paragraphes suivants décrivent les différents systèmes de sécurité permettant au chauffe-air de fonctionner de façon toujours sécuritaire.

Plenum Overheating Detection

The SB and SB-M duct heater control board is able to detect if the temperature of the plenum exceeds a certain critical point at which the operation could lead to premature wear of the elements and an overheating of the unit. For instance a dirty air filter could reduce the circulation of air in the conduits to the point where it becomes insufficient to dissipate all the heat generated by the elements or the burner of the furnace. As a result the temperature of the plenum would rise above the first threshold point fixed at 68°C. In this situation the control board will only indicate this event by means of a diagnostic pilot light (red). The pilot light will blink 4 times in two seconds, followed by a two second pause. The indication of the problem can be re-initialized using the heating mode selector button. No action other than the indication of an overheating will take place at this time.

In fuel mode, if the temperature of the plenum exceeds 71°C for more than two minutes (most likely the result of a very dirty filter), the control board will switch from fuel mode to electric mode in order to lower the temperature.

In electric mode, if the temperature of the plenum exceeds 71°C for more than two minutes, the electric elements (max. 4) will be deactivated progressively, by the minute, until the temperature of the plenum is below 71°C. If the temperature drops below 54°C, the deactivated elements will be reactivated progressively until the temperature of the plenum is above 54°C.

Thermal Protections

The SB dual energy duct heater is equipped with a thermo-mechanical protection, which provides the ultimate line of defence against any possible overheating. Each element has its own automatic reset thermal protection, which protects it from overheating. Moreover, a manual reset thermal protection has been installed in the duct heater in case the elements automatic protection should fail. The automatic thermal protection of the element opens at 71°C (140°F) where as the manual thermal protection opens at 60°C (165°F).

Heating demand interlock (“SB” only)

The demand for heat received by the control board can only operate one heating mode at a time even if the microcontroller is damaged. Indeed, an electro-mechanical interlock built in the control board (Relay K1 see page 17), prevents the two heating modes from operating at the same time as a result from a damaged microcontroller requesting erratic demands.

MAINTENANCE

The SB & SB-M dual energy duct heater itself does not require any particular maintenance. However, it is important to carry out regular maintenance on the ventilation system as a whole. The air filter should be replaced when it is dirty and the ventilation shafts cleaned out when necessary. During the cleaning of the conduits, the ventilator of the furnace must be inspected and cleaned if necessary. A faulty maintenance of the ventilation system will reduce the performance of the duct heater.

N.B. : Never activate the duct heater if the ventilation system is not equipped with an air filter.

REPLACEMENT COMPONENT LIST

#DIAGRAM	#PART	DESCRIPTION
1	ELF-SB160521	SB ASSEMBLED ELEMENT, 16” LONG., 5 kW, 240 V
1	ELF-SB160421	SB ASSEMBLED ELEMENT, 16” LONG., 4 kW, 240 V
1	ELF-SB160321	SB ASSEMBLED ELEMENT, 16” LONG., 3.5 kW, 240 V
1	ELF-SB190521	SB ASSEMBLED ELEMENT, 19” LONG., 5 kW, 240 V
1	ELF-SB190421	SB ASSEMBLED ELEMENT, 19” LONG., 4 kW, 240 V
1	ELF-SB190321	SB ASSEMBLED ELEMENT, 19” LONG., 3.5 kW, 240 V
2	PROT-065	THERMAL PROTECTION, 165°F, MANUAL RESET
3	PROT-019	THERMAL PROTECTION, 140°F, AUTOMATIC RESET
4	CIR-001	SB ELECTRONIC CONTROL CARD
5	CON-010A	CONNECTOR/WIRES ASSEMBLY, RELAYS OUTPUTS SB
6	TRF200040D	TRANSFORMER, 208-240/24/40VA, CL.2 CL.B
7	REL-007	RELAY, T9AP5D52-2A - N.O. 20A; N.C., 10A
8	REL-006	RELAY, FR4A COIL DC 24V, N.O 30A/250VAC
9	TRI-001	TRIAC, 40A, 600V, PANEL MOUNT, BTA40

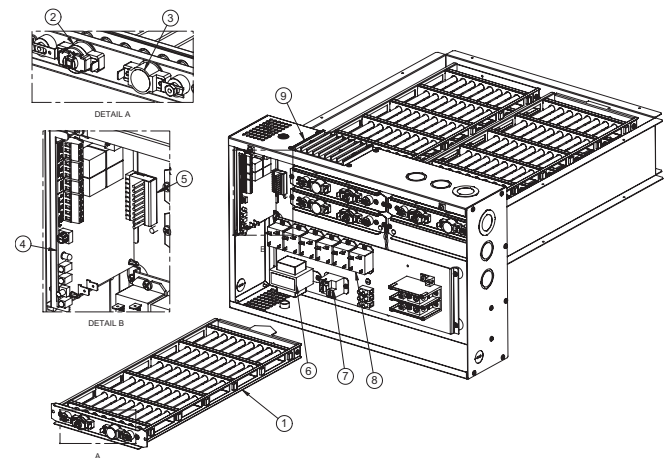

Limited warranty

This limited warranty is offered by Stelpro Design inc. ("Stelpro") and applies to the following products made by Stelpro: models SB & SB-M. **Please read this limited warranty carefully.** Subject to the terms of this warranty, Stelpro warrants its products and their components against defects in workmanship and/or materials for the following period from the date of purchase: **5 years**. This warranty applies only to the original purchaser; it is non-transferable and cannot be extended.

Claim procedure

If at any time during the warranty period the unit becomes defective, you must cut off the power supply at the main electrical panel and contact 1) your installer or distributor, 2) your service center or 3) Stelpro's customer service department. In all cases, you must have a **copy of the invoice** and provide the **information written on the product nameplate**. Stelpro reserves the right to examine or to ask one of its representatives to examine the product itself or any part of it before honoring the warranty. Stelpro reserves the right to replace the entire unit, refund its purchase price or repair a defective part. Please note that repairs made within the warranty period must be authorized in advance in writing by Stelpro and carried out by persons authorized by Stelpro.

Before returning a product to Stelpro, you must have a Stelpro authorization number (RMA). To obtain it, call the customer service department at: **1-800-363-3414** (electricians and distributors - French), **1-800-343-1022** (electricians and distributors - English), or **1-866-766-6020** (consumers). The authorization number must be clearly written on the parcel or it will be refused.

Conditions, exclusions and disclaimer of liability

This warranty is exclusive and in lieu of all other representations and warranties (except of title), expressed or implied, and Stelpro expressly disclaims and excludes any implied warranty of merchantability or implied warranty of fitness for a particular purpose.

Stelpro's liability with respect to products is limited as provided above. Stelpro shall not be subject to any other obligations or liabilities whatsoever, whether based on contract, tort or other theories of law, with respect to goods or services furnished by it, or any undertakings, acts or omissions relating thereto. Without limiting the generality of the foregoing, Stelpro expressly disclaims any liability for property or personal injury damages, penalties, special or punitive damages, damages for lost profits, loss of use of equipment, cost of capital, cost of substitute products, facilities or services, shutdowns, slowdowns, or for other types of economic loss or for claims of a dealer's customers or any third party for such damages. Stelpro specifically disclaims all consequential, incidental and contingent damages whatsoever.

This warranty does not cover any damages or failures resulting from: 1) a faulty installation or improper storage; 2) an abusive or abnormal use, lack of maintenance, improper maintenance (other than that prescribed by Stelpro) or a use other than that for which the unit was designed; 3) a natural disaster or an event out of Stelpro's control, including, but not limited to, hurricanes, tornadoes, earthquakes, terrorist attacks, wars, overvoltage, flooding, water damages, etc. This warranty does not cover any accidental or intentional losses or damages, nor does it cover damages caused by negligence of the user or owner of the product. Moreover, it does not cover the cost of disconnection, transport, and installation.

The warranty is limited to the repair or the replacement of the unit or the refund of its purchase price, **at the discretion of Stelpro**. Any parts replaced or repaired within the warranty period with the written authorization of Stelpro will be warranted for the remainder of the original warranty period. This warranty will be considered null and void and Stelpro will have the right to refuse any claims if **products have been altered** without the written authorization of Stelpro and if the nameplate numbers have been removed or modified. This warranty does not cover scratches, dents, corrosion or discoloration caused by excessive heat, chemical cleaning products and abrasive agents. It does not cover any damage that occurred during the shipping.

Some states and provinces do not allow the exclusion or limitation of incidental or consequential damages and some of them do not allow limitations on how long an implied warranty lasts, so these exclusions or limitations may not apply to you. This warranty gives you specific legal rights and you may have other rights which vary from state to state or from province to province.



E322241

Stelpro Design Inc.
Saint-Bruno-de-Montarville (Quebec) J3V 6L7