

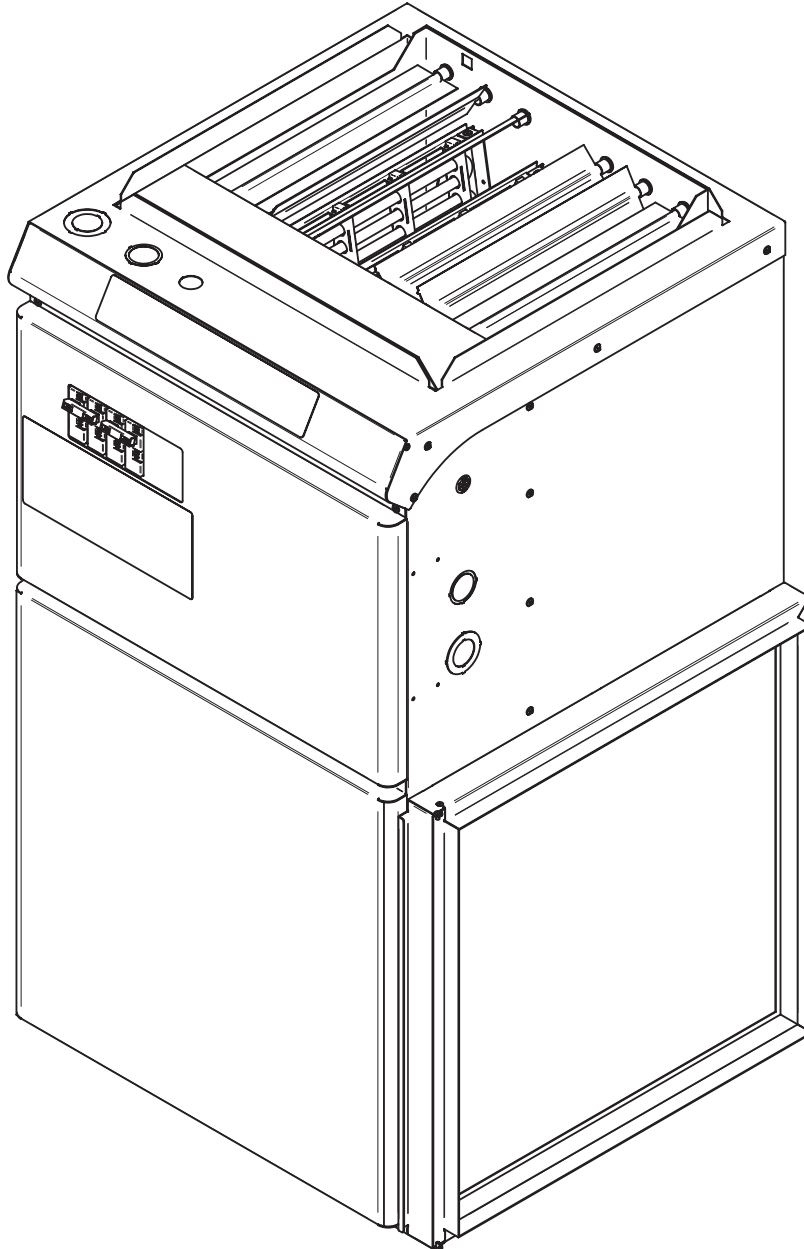

# USER'S GUIDE

## SEFE SERIES ELECTRIC FURNACE

REPLACEMENT COMPONENT LIST INCLUDED



This unit  
complies with  
CSA and UL  
standards



This unit is approved according  
to the Canadian and American  
manufacturing standards.

**This section must be read carefully by the installer.  
The installer must also read the user's guide since it contains other important information.**



## WARNING

Before installing and operating this product, the user and/or installer must read, understand and follow these instructions and keep them handy for future reference. If these instructions are not followed, the warranty will be considered null and void and the manufacturer deems no further responsibility for this product.

This product must be installed by a qualified person and connected by a **certified electrician**, according to the **electrical** and **building codes** effective in your region.

The following instructions must be adhered to in order to avoid personal injuries or property damages, serious injuries and potentially fatal electric shocks.

Protect the heating unit with the appropriate circuit breaker or fuse, in accordance with the nameplate.

Make sure the line voltage (volt) is consistent with that indicated on the unit's nameplate.

This unit **must be grounded**.

Switch off the power at the circuit breaker/fuse before installing, repairing and cleaning the unit.

Make sure the unit is appropriate for the intended use (if needed, refer to the product catalog or a representative).

If the unit's capacity is insufficient for the size of the house, it will be in operation continuously, and may become prematurely defective.

**Respect distances and positions** indicated in the installation section.

If the installer or user modifies the unit, they will be held responsible for any damage resulting from this modification, and the CSA certification will be void.

This unit must not come into contact with a water source and must be protected from splashes (e.g. a wet mop). Do not use if any part has been immersed. Moreover, do not turn it on or off when standing in water or if your hands are wet.

When cutting a piece of steel for the installation of the return duct, be careful not to damage the electrical wiring of the unit.

Because this unit is hot when in use, it may pose risks even in normal operation. Therefore, be **careful** and **responsible** when using it. To avoid burns, do not let bare skin touch hot surfaces. Let the unit cool down for a few minutes before handling (it stays warm for some time after shut-down).

Never block air vents. This obstruction could lead to overheating, which could result in a fire.

Do not insert or allow foreign objects to enter any air vent as this may cause electric shocks, fires, or damages to the unit.

This unit has hot and arcing or sparking parts inside. It is not designed to be used or stored in wet areas or areas containing flammable liquids, combustible materials or corrosive, abrasive, chemical, explosive and flammable substances such as, but not limited to, gasoline, paint, chlorine and cleaning products.

Some areas are dustier than others. Thus, it is the user's responsibility to evaluate if the **filter must be changed** based on the amount of dirt accumulated on it. Accumulated dirt can lead to a component malfunction or discoloration (yellowing). It may cause a fire hazard if not installed and maintained in accordance with these instructions.

Thermal protection activation indicates that the unit has been subjected to abnormal operating conditions. If the thermal protection remains activated or activates and deactivates repeatedly, it is recommended that a qualified electrician or a certified repair centre examine the unit in order to make sure it is not damaged. (Refer to the LIMITED WARRANTY).

If the unit is damaged or defective, cut off power supply at circuit breaker/fuse and call a certified repair centre. (Refer to the LIMITED WARRANTY).

Label all wires prior to disconnection when servicing controls. Wiring errors can cause improper and dangerous operation.



**Note:** When a part of the product specification must be changed to improve operability or other functions, priority is given to the product specification itself. In such instances, the instruction manual may not entirely match all the functions of the actual product. Therefore, the actual product and packaging, as well as the name and illustration, may differ from the manual.

## OPERATION

The SEFE furnace is equipped with a user-friendly control panel. It includes five buttons and seven pilot lights (see explanations below).

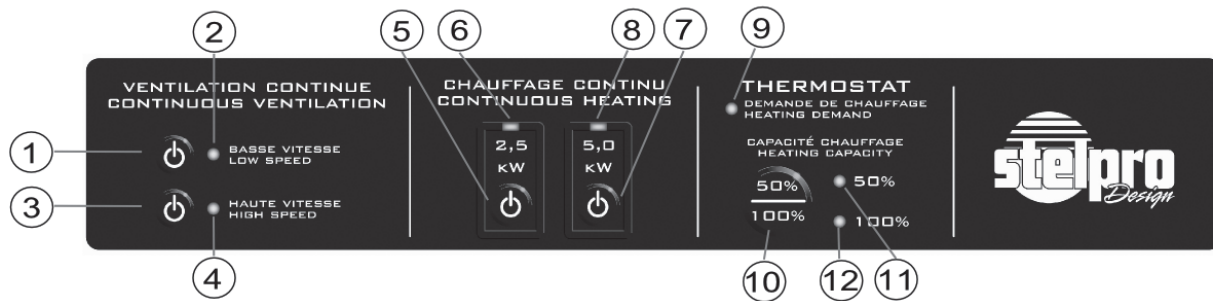

### LEGEND

- 1. LOW SPEED CONTINUOUS VENTILATION** button: provides the selection of the low speed continuous ventilation mode.
- 2. LOW SPEED CONTINUOUS VENTILATION** pilot light: indicates that the low speed continuous ventilation mode is activated.
- 3. HIGH SPEED CONTINUOUS VENTILATION** button: provides the selection of the high speed continuous ventilation mode.
- 4. HIGH SPEED CONTINUOUS VENTILATION** pilot light: indicates that the high speed continuous ventilation mode is activated.
- 5. 2.5 kW CONTINUOUS HEATING** button: provides the selection of the 2.5 kW continuous heating mode.
- 6. 2.5 kW CONTINUOUS HEATING** pilot light: indicates that the 2.5 kW continuous heating mode is activated. This mode is pending if the pilot light is blinking (see CONTINUOUS HEATING section below).
- 7. 5 kW CONTINUOUS HEATING** button: provides the selection of the 5 kW continuous heating mode.
- 8. 5 kW CONTINUOUS HEATING** pilot light: indicates that the 5 kW continuous heating mode is activated. This mode is pending if the pilot light is blinking (see CONTINUOUS HEATING section below).
- 9. THERMOSTAT** pilot light: indicates that the furnace is receiving a heating demand from the thermostat.
- 10. 50% or 100% HEATING CAPACITY** buttons: allow to choose the heating capacity of the furnace in case of a heating demand from the thermostat. Two possible capacities: 50% or 100%.
- 11. 50% pilot light:** indicates that the selected heating capacity is 50%.
- 12. 100% pilot light:** indicates that the selected heating capacity is 100%.

## CONTINUOUS VENTILATION MODES

One of the benefits of your SEFE furnace, is the possibility to ventilate your house. The control panel includes two continuous ventilation speeds (low and high).

### LOW SPEED CONTINUOUS VENTILATION

Use low speed continuous ventilation all year for maximum comfort due to constant air temperature. If your central heating system is equipped with an efficient filter and you use the low speed continuous ventilation all year long, the air in your house will be healthier as it will be permanently filtered. Continuous ventilation will also have a positive effect on air humidification if your system includes a humidifier.

### HIGH SPEED CONTINUOUS VENTILATION

If you do not have an air-conditioner, the high speed continuous ventilation mode is perfect during hot sunny days. In this mode, the furnace blower provides a powerful airflow that quickly circulates throughout the house.

If a continuous ventilation mode is activated when there is a heating demand, it is temporarily deactivated to allow the blower to switch heating speed. The pilot light indicating the selected continuous ventilation mode will however remain on to indicate that the continuous ventilation will start again at the selected speed once the heating demand is satisfied.

## CONTINUOUS HEATING MODES

Air temperature variations in your house have a huge impact on your comfort. The SEFE furnace offers a continuous heating mode minimizing temperature variations between heating demands from the thermostat.

If you feel uncomfortable temperature variations when it is cold outside, activate the 2.5 kw continuous heating mode. For more power, simply activate the 5 kw continuous heating mode.

Note that if you choose to activate the continuous heating mode, the low speed continuous ventilation will automatically be activated. It is also possible to select the high speed continuous ventilation when the continuous heating mode is activated.

The continuous heating mode automatically switches into stand-by mode at the end of the heating season and it is automatically reactivated at the beginning of the next heating season.

Consequently, you do not have to deactivate this mode in summer. When in stand-by, the LED pilot light indicating the selected continuous heating mode (2.5 kw or 5 kw) will blink. You can deactivate it at any time by pressing on the button corresponding to the activated mode (2.5 kw or 5 kw).

## HEATING CAPACITY SELECTION (50% OU 100%)

At the beginning and the end of the heating season, the weather is more mild than in the middle of winter. So, your house may not require the full capacity of your SEFE furnace. That is why the control panel includes a button that enables you to choose between 50% or 100% capacity.

In spring and fall, select the 50% capacity mode to reduce the heating power by about half, when there is a heating demand from the thermostat. This will increase your comfort while allowing you to make energy savings. In the middle of the heating season, it is recommended to select the 100% capacity mode.

**N.B. If the furnace is connected to a two-stage thermostat, the furnace heating capacity must always be set at 50%. If not, you will not enjoy the benefit of this type of thermostat.**

## MAINTENANCE

**N.B. In order for the warranty to be valid, the unit must be cleaned regularly.**

Cut off power supply at circuit breaker/fuse before cleaning the unit. Use a soft rag for dusting. When cleaning, use only a damp rag and non-abrasive dish soap. Do not use abrasive or chemical cleaners because they may damage the finish. If the unit is used in a very dusty location, use a vacuum brush to remove dust and other foreign objects from the grills. Note that cigarette smoke could yellow the discharge grill and that the best way to prevent it is to clean the unit on a regular basis.

**Do not use cleaning products identified with these symbols:**



**N.B. There is electrical current linked to the unit even if the thermostat is set off. This means that there is a risk of electric shock as long as the unit is energized.**

### PREVENTIVE MAINTENANCE

Do not try to repair your furnace yourself. Call a qualified technician. However, before calling a technician, check the following points.

1. Make sure fuses or circuit breakers are activated.
2. Adjust the temperature set point of the thermostat above the ambient temperature. If heating does not start, cut off the power supply and call a technician.

**N.B. When calling a technician for maintenance or to order a replacement part, specify the model of your furnace as well as its serial number.**

### AIR FILTER

Excessive dust or dirt accumulation can block the airflow, forcing the unit to work harder to maintain the desired temperature. Therefore, it uses more energy and increases heating costs.

Since the air filter supplied is disposable, you should replace it two to four times a year, according to the model used and the installation area. Dirtier areas can require more than four filter changes.

To replace a dirty filter, open the access door to the filter, remove the old filter and insert the new one inside the rack. Make sure the new filter has the same technical specifications and size as the previous one.

**N.B. Never operate the unit without a filter in place.**

Every time a filter is changed, you should check the following points.

- Excessive accumulation of dirt or dust on furnace components.
- Damaged components or surfaces.
- Presence of water inside or outside the furnace.

If you encounter any of these problems, do not operate the furnace. Call a qualified technician.

### BLOWER

The blower motor is sealed and permanently lubricated, so it is not necessary to lubricate it.

Even if you change the filter frequently, the blower's blades and motors will become dust laden after a few months. The entire blower assembly should be inspected annually. If needed, vacuum out the dust. If you cannot clean the blower without removing it from the furnace, this service must be performed by a qualified technician.

## TROUBLESHOOTING

PROBLEM	DEFECTIVE PART OR PART TO CHECK
The unit does not work	<ul style="list-style-type: none"> <li>- Defective thermostat or wrong thermostat setting or location</li> <li>- Open circuit breaker or fuse</li> </ul>
The unit runs continuously	<ul style="list-style-type: none"> <li>- Blower control switch is on the continuous position</li> </ul>
Overheating	<ul style="list-style-type: none"> <li>- Defective motor</li> <li>- Defective thermostat or wrong thermostat setting or location</li> <li>- Dirty or blocked filter</li> </ul>
The on/off cycles of the motor are too short or too long	<ul style="list-style-type: none"> <li>- The heat anticipator is incorrectly set or is burned out (if applicable)</li> </ul>
The thermostat must be set at a much higher or lower temperature than the desired ambient temperature	<ul style="list-style-type: none"> <li>- The thermostat is not level, needs calibration or is installed in an improper location</li> </ul>
The desired room temperature cannot be reached	<ul style="list-style-type: none"> <li>- The thermal protection opens the circuit because of duct obstructions or dirty filters</li> </ul>

**N.B. If you do not solve the problem after checking these points, cut off the power supply at the main electrical panel and contact our customer service (see the LIMITED WARRANTY section to obtain the phone numbers).**

# REPLACEMENT COMPONENT LIST

REF. #	PART #	DESCRIPTION
1	ELF-SEF0521	ELEMENT ASSEMBLY 5 KW
1	ELF-SEF0421	ELEMENT ASSEMBLY 4 KW
1	ELF-SEF0221	ELEMENT ASSEMBLY 2 X 2, 5 KW
2	BLO-004	SQUIRREL CAGE & BLOWER 10-8
2	BLO-005	SQUIRREL CAGE & BLOWER 12-11
3	MO-036-1	MOTOR 208-230 VAC, 1 PH, 1/3 HP, 4 SPEEDS, 1075 RPM
3	MO-037	MOTOR 240 VAC, 1 PH, 1 HP, 3 SPEEDS, 1075 RPM
3	SUP-004	MOTOR SUPPORT FOR BLO-004
3	SUP-002	MOTOR SUPPORT FOR BLO-005
4	PROT-010	THERMAL PROTECTION L-160-40 - 10 KW TO 23 KW
4	PROT-019	THERMAL PROTECTION L-140-40 - 27 KW & 30 KW
5	CAP-010	CAPACITOR 6 UF AT 370 VAC
5	CAP-002	CAPACITOR 20 UF AT 370 VAC
6	REL-006	RELAY, SPST, 30 A, 24 VDC
7	SEN-002	TEMPERATURE SENSOR
8	PAD-004	MEMBRANE KEYPAD, SEFE/SEFECM FURNACES
9	CIR-003-SEFE1021	MAIN CONTROL CARD SEFE1021
9	CIR-003-SEFE1521	MAIN CONTROL CARD SEFE1521
9	CIR-003-SEFE1821	MAIN CONTROL CARD SEFE1821
9	CIR-003-SEFE2021	MAIN CONTROL CARD SEFE2021
9	CIR-003-SEFE2321	MAIN CONTROL CARD SEFE2321
9	CIR-003-SEFE2721	MAIN CONTROL CARD SEFE2721
9	CIR-003-SEFE3021	MAIN CONTROL CARD SEFE3021
10	TRF200040D	TRANSFORMER, 240/208-24 VAC, 40 VA
11	BREA-001	CIRCUIT BREAKER, 120/240 VAC, 30 A, 2 P
11	BREA-002	CIRCUIT BREAKER, 120/240 VAC, 40 A, 2 P
11	BREA-003	CIRCUIT BREAKER, 120/240 VAC, 50 A, 2 P

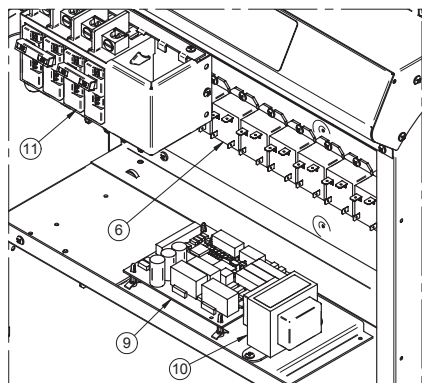

DETAIL A

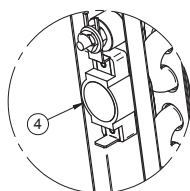

DETAIL B

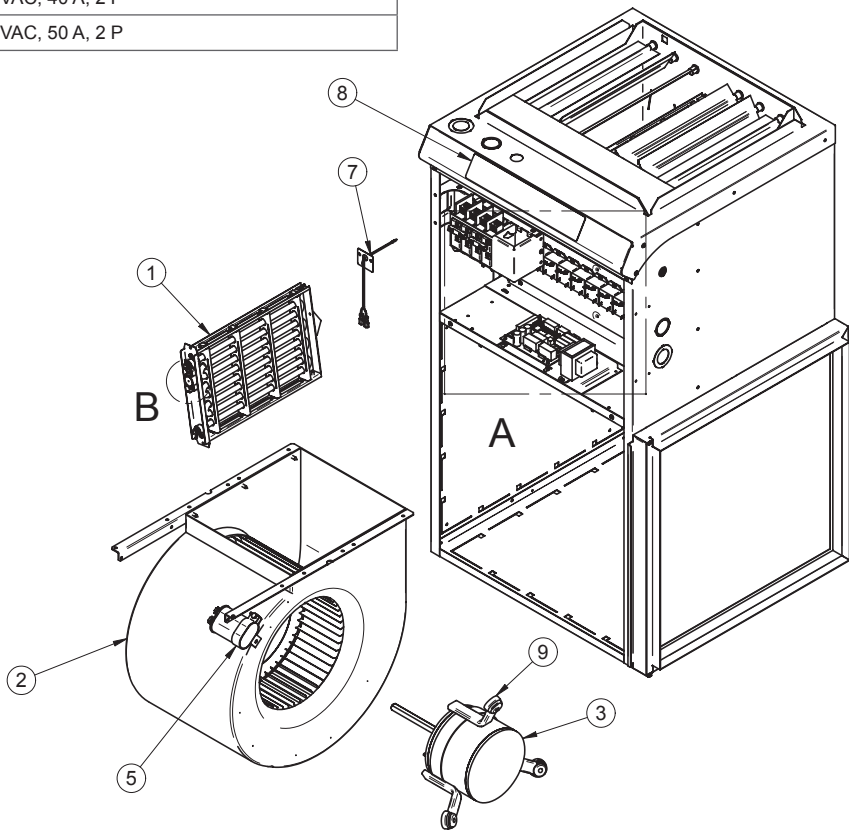

# LIMITED WARRANTY

This limited warranty is offered by Stelpro Design inc. ("Stelpro") and applies to the following products made by Stelpro: SEFE10, SEFE15, SEFE18, SEFE20, SEFE23, SEFE27, SEFE30 models. **Please read this limited warranty carefully.** Subject to the terms of this warranty, Stelpro warrants its products and their components against defects in workmanship and/or materials for the following periods from the date of purchase: **5 years.** This warranty applies only to the original purchaser; it is non-transferable and cannot be extended.

## CLAIM PROCEDURE

If at any time during the warranty period the unit becomes defective, you must cut off the power supply at the main electrical panel and contact 1) your installer or distributor, 2) your service center or 3) Stelpro's customer service department. In all cases, you must have a **copy of the invoice** and provide the **information written on the product nameplate.** Stelpro reserves the right to examine or to ask one of its representatives to examine the product itself or any part of it before honoring the warranty. Stelpro reserves the right to replace the entire unit, refund its purchase price or repair a defective part. Please note that repairs made within the warranty period must be authorized in advance in writing by Stelpro and carried out by persons authorized by Stelpro.

Before returning a product to Stelpro, you must have a Stelpro authorization number (RMA). To obtain it, call the customer service department at: **1-800-363-3414** (electricians and distributors - French), **1-800-343-1022** (electricians and distributors - English), or **1-866-766-6020** (consumers). The authorization number must be clearly written on the parcel or it will be refused.

## CONDITIONS, EXCLUSIONS AND DISCLAIMER OF LIABILITY

This warranty is exclusive and in lieu of all other representations and warranties (except of title), expressed or implied, and Stelpro expressly disclaims and excludes any implied warranty of merchantability or implied warranty of fitness for a particular purpose.

Stelpro's liability with respect to products is limited as provided above. Stelpro shall not be subject to any other obligations or liabilities whatsoever, whether based on contract, tort or other theories of law, with respect to goods or services furnished by it, or any undertakings, acts or omissions relating thereto. Without limiting the generality of the foregoing, Stelpro expressly disclaims any liability for property or personal injury damages, penalties, special or punitive damages, damages for lost profits, loss of use of equipment, cost of capital, cost of substitute products, facilities or services, shutdowns, slowdowns, or for other types of economic loss or for claims of a dealer's customers or any third party for such damages. Stelpro specifically disclaims all consequential, incidental and contingent damages whatsoever.

This warranty does not cover any damages or failures resulting from: 1) a faulty installation or improper storage; 2) an abusive or abnormal use, lack of maintenance, improper maintenance (other than that prescribed by Stelpro) or a use other than that for which the unit was designed; 3) a natural disaster or an event out of Stelpro's control, including, but not limited to, hurricanes, tornadoes, earthquakes, terrorist attacks, wars, overvoltage, flooding, water damages, etc. This warranty does not cover any accidental or intentional losses or damages, nor does it cover damages caused by negligence of the user or owner of the product. Moreover, it does not cover the cost of disconnection, transport, and installation.

The warranty is limited to the repair or the replacement of the unit or the refund of its purchase price, **at the discretion of Stelpro.** Any parts replaced or repaired within the warranty period with the written authorization of Stelpro will be warranted for the remainder of the original warranty period. This warranty will be considered null and void and Stelpro will have the right to refuse any claims if **products have been altered** without the written authorization of Stelpro and if the nameplate numbers have been removed or modified. This warranty does not cover scratches, dents, corrosion or discoloration caused by excessive heat, chemical cleaning products and abrasive agents. It does not cover any damage that occurred during the shipping.

Some states and provinces do not allow the exclusion or limitation of incidental or consequential damages and some of them do not allow limitations on how long an implied warranty lasts, so these exclusions or limitations may not apply to you. This warranty gives you specific legal rights and you may have other rights which vary from state to state or from province to province.