

User's guide

“SFR” series Air Filter Rack

Replacement components list included

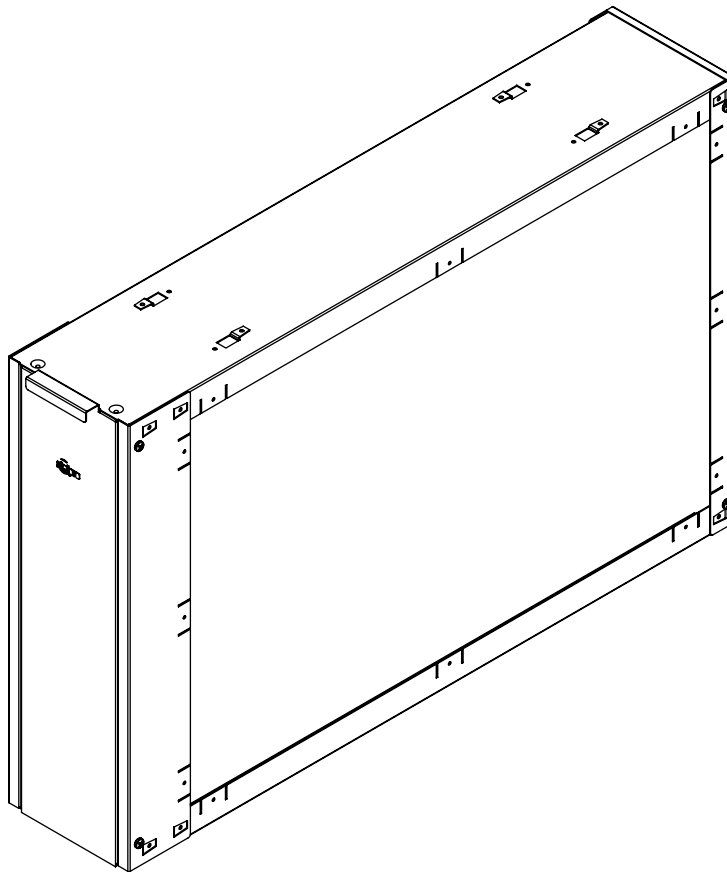

For further information or to consult this guide on line, please visit our Web site.

⚠ WARNING ⚠ WARNING ⚠ WARNING ⚠ WARNING ⚠

Before installing and operating this product, the user and/or installer must read, understand and follow these instructions and keep them handy for future reference. If these instructions are not followed, the warranty will be considered null and void and the manufacturer deems no further responsibility for this product.

Switch off the power at the circuit breaker/fuse before installing, repairing and cleaning the unit.

Make sure the filter is appropriate for the intended use (if needed, refer to the product catalog or a representative).

Regularly verify and replace if required.

Respect positions indicated in the installation section.

Some areas are dustier than others. Thus, it is the user's responsibility to evaluate if the unit **must be cleaned** based on the amount of dirt accumulated on and inside air vents.

It is strongly recommended to change or clean the filter each 4 to 6 months.

SELECTION TABLE

Type	Description
SF16253	Filter 16 x 25 x 3 in. merv 7
SF16254	Filter 16 x 25 x 4 in. merv 8
SF16255	Filter 16 x 25 x 5 in. merv 11
SF20204	Filter 20 x 20 x 4 in. merv 8
SF20205	Filter 20 x 20 x 5 in. merv 11
SF20254	Filter 20 x 25 x 4 in. merv 8
SF20255	Filter 20 x 25 x 5 in. merv 11
SFR16255	Filter rack 16 x 25 x 5 in.
SFR16256	Filter rack 16 x 25 x 6 in.
SFR20205	Filter rack 20 x 20 x 5 in.
SFR20206	Filter rack 20 x 20 x 6 in.
SFR20255	Filter rack 20 x 25 x 5 in.
SFR20256	Filter rack 20 x 25 x 6 in.
SFRF16253	Filter rack and filter 16 x 25 x 3 in.
SFRF16254	Filter rack and filter 16 x 25 x 4 in.
SFRF16255	Filter rack and filter 16 x 25 x 5 in.
SFRF20204	Filter rack and filter 20 x 20 x 4 in.
SFRF20205	Filter rack and filter 20 x 20 x 5 in.
SFRF20254	Filter rack and filter 20 x 25 x 4 in.
SFRF20255	Filter rack and filter 20 x 25 x 5 in.

TECHNICAL DRAWINGS

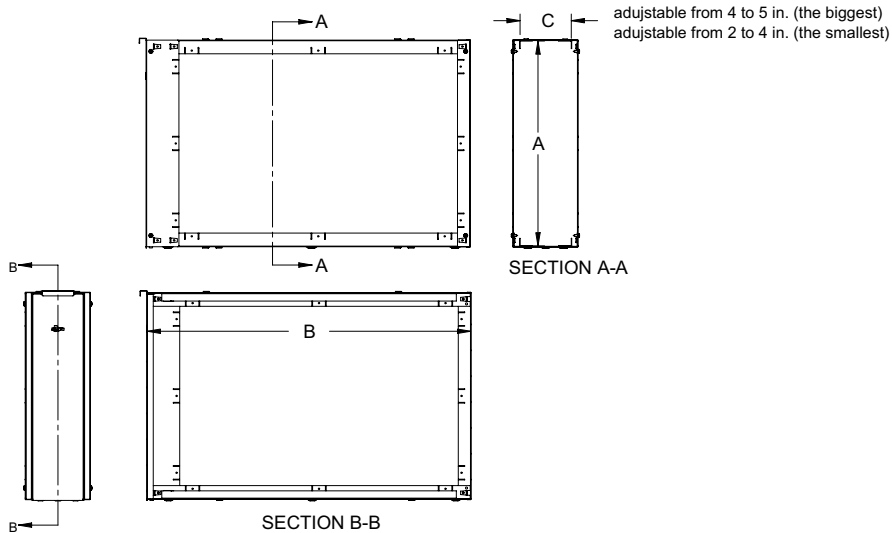

INSTALLATION

Cut off power supply at circuit breaker/fuse before proceeding to installation.

1. Open the door of the compartment where the filter must be installed.
2. Remove the new filter from its packaging and insert it into the filter rack. Pay attention to the direction of the filter; you must respect the direction of the arrows indicating the direction of the airflow.
3. Close the filter rack door.
4. Restore the power supply of the furnace at circuit breaker/fuse and turn it on to check if it works well.

N.B. If you encounter a problem after turning the furnace on, turn it off and check out the filter installation again. If required, contact our customer service (see the "Limited warranty" section to obtain the phone numbers).

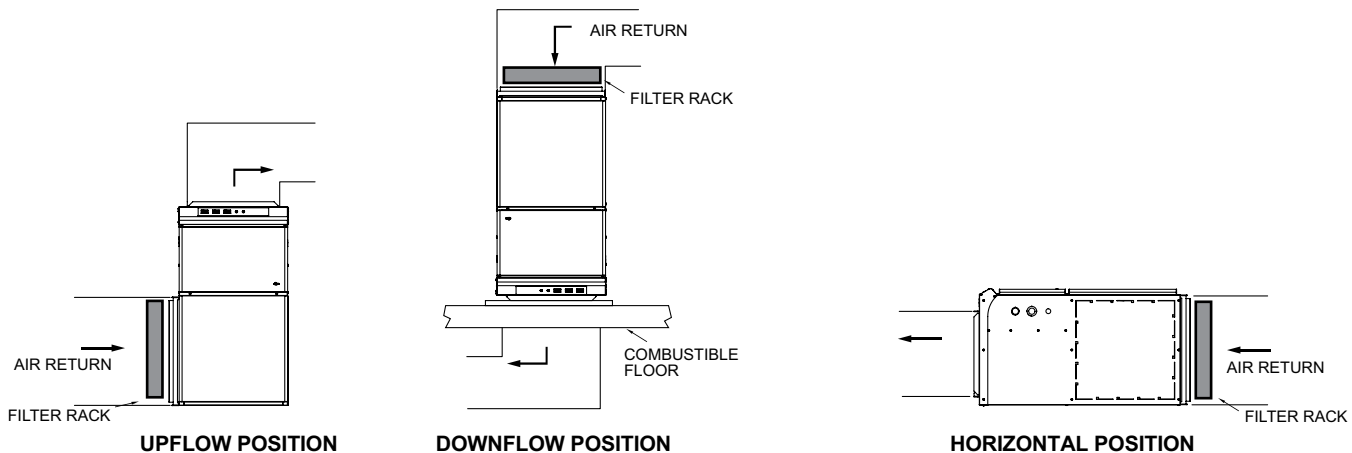

MAINTENANCE

Cut off power supply at circuit breaker/fuse before proceeding to maintenance.

When used under normal operating conditions, the useful life of a filter is approximately 4 to 6 months (at the end of the heating or the cooling season). That means that you must replace it roughly 2 to 3 times a year, depending of where the furnace is placed. In fact, it is very simple to determine if a filter needs to be replaced; you only have to proceed to a visual inspection and evaluate if the amount of dirt and dust can affect its good performance.

Do not use cleaning products identified with these symbols:   

REPLACEMENT COMPONENT LIST

# REF.	# PART	DESCRIPTION
1	SFRF16253	Filter rack 16 x 25 x 3 in.
1	SFRF16254	Filter rack 16 x 20 x 4 in.
1	SFRF16255	Filter rack 16 x 25 x 5 in.
1	SFRF20204	Filter rack 20 x 20 x 4 in.
1	SFRF20205	Filter rack 20 x 20 x 5 in.
1	SFRF20254	Filter rack 20 x 25 x 4 in.
1	SFRF20255	Filter rack 20 x 25 x 5 in.
2	SF16253-BULK	Filter 16 x 25 x 3 in. merv 7 (bulk)
2	SF16254-BULK	Filter 16 x 25 x 4 in. merv 8 (bulk)
2	SF16255-BULK	Filter 16 x 25 x 5 in. merv 11 (bulk)
2	SF20204-BULK	Filter 20 x 20 x 4 in. merv 8 (bulk)
2	SF20205-BULK	Filter 20 x 20 x 3 in. merv 11 (bulk)
2	SF20254-BULK	Filter 20 x 25 x 4 in. merv 8 (bulk)
2	SF20255-BULK	Filter 20"x 25 x 5 in. merv 11 (bulk)
3	M-SFR406Z1	Door (charcoal)

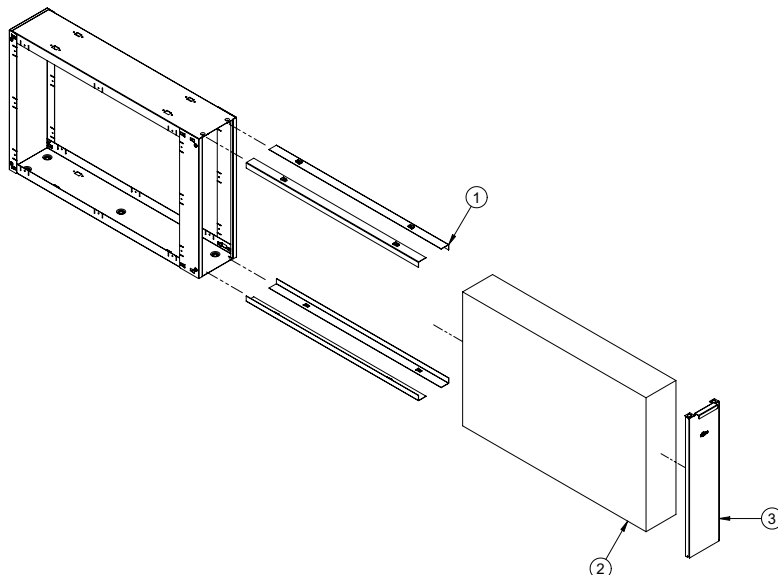

Limited warranty

This limited warranty is offered by Stelpro Design inc. ("Stelpro") and applies to the following product made by Stelpro: model SFR. **Please read this limited warranty carefully.** Subject to the terms of this warranty, Stelpro warrants its products and their components against defects in workmanship and/or materials for the following periods from the date of purchase: **1 year (filter rack)**. This warranty applies only to the original purchaser; it is non-transferable and cannot be extended.

Claim procedure

If at any time during the warranty period the unit becomes defective, you must cut off the power supply at the main electrical panel and contact 1) your installer or distributor, 2) your service center or 3) Stelpro's customer service department. In all cases, you must have a **copy of the invoice** and provide the **information written on the product nameplate**. Stelpro reserves the right to examine or to ask one of its representatives to examine the product itself or any part of it before honoring the warranty. Stelpro reserves the right to replace the entire unit, refund its purchase price or repair a defective part. Please note that repairs made within the warranty period must be authorized in advance in writing by Stelpro and carried out by persons authorized by Stelpro.

Before returning a product to Stelpro, you must have a Stelpro authorization number (RMA). To obtain it, call the customer service department at: **1-800-363-3414** (electricians and distributors - French), **1-800-343-1022** (electricians and distributors - English), or **1-866-766-6020** (consumers). The authorization number must be clearly written on the parcel or it will be refused.

Conditions, exclusions and disclaimer of liability

This warranty is exclusive and in lieu of all other representations and warranties (except of title), expressed or implied, and Stelpro expressly disclaims and excludes any implied warranty of merchantability or implied warranty of fitness for a particular purpose.

Stelpro's liability with respect to products is limited as provided above. Stelpro shall not be subject to any other obligations or liabilities whatsoever, whether based on contract, tort or other theories of law, with respect to goods or services furnished by it, or any undertakings, acts or omissions relating thereto. Without limiting the generality of the foregoing, Stelpro expressly disclaims any liability for property or personal injury damages, penalties, special or punitive damages, damages for lost profits, loss of use of equipment, cost of capital, cost of substitute products, facilities or services, shutdowns, slowdowns, or for other types of economic loss or for claims of a dealer's customers or any third party for such damages. Stelpro specifically disclaims all consequential, incidental and contingent damages whatsoever.

This warranty does not cover any damages or failures resulting from: 1) a faulty installation or improper storage; 2) an abusive or abnormal use, lack of maintenance, improper maintenance (other than that prescribed by Stelpro) or a use other than that for which the unit was designed; 3) a natural disaster or an event out of Stelpro's control, including, but not limited to, hurricanes, tornadoes, earthquakes, terrorist attacks, wars, overvoltage, flooding, water damages, etc. This warranty does not cover any accidental or intentional losses or damages, nor does it cover damages caused by negligence of the user or owner of the product. Moreover, it does not cover the cost of disconnection, transport, and installation.

The warranty is limited to the repair or the replacement of the unit or the refund of its purchase price, **at the discretion of Stelpro**. Any parts replaced or repaired within the warranty period with the written authorization of Stelpro will be warranted for the remainder of the original warranty period. This warranty will be considered null and void and Stelpro will have the right to refuse any claims if **products have been altered** without the written authorization of Stelpro and if the nameplate numbers have been removed or modified. This warranty does not cover scratches, dents, corrosion or discoloration caused by excessive heat, chemical cleaning products and abrasive agents. It does not cover any damage that occurred during the shipping.

Some states and provinces do not allow the exclusion or limitation of incidental or consequential damages and some of them do not allow limitations on how long an implied warranty lasts, so these exclusions or limitations may not apply to you. This warranty gives you specific legal rights and you may have other rights which vary from state to state or from province to province.