



IMPORTANT INSTRUCTIONS

WARNING

Before installing and using this product, you must read and understand these instructions and keep them for future reference. If the installer and the user do not follow these instructions, the manufacturer cannot be held liable in any way and the warranty will be null and void.

1. Read all instructions before using this heater.
2. Use this heater only as described in this manual. Any other use not recommended by the manufacturer could cause fire, electric shock or serious injury to persons.
3. If the installer or user modifies the heater, they will be held responsible for any damage resulting from this modification, and the UL certification may be voided.
4. Do not use outdoors.

5. Make sure the unit is designed for its intended use (if necessary, refer to the product catalog or a representative). This product must be used in accordance with the electrical and building codes in effect in your area.
 6. Observe the distances and positions mentioned in the installation section of this guide.
 7. You must leave a minimum of 6 in. (15.2 cm) of clearance between the unit's air inlet and the walls of the room where the unit is installed. Furthermore, certain materials are more sensitive to heat than others, you must assure that these materials are located at a proper proximity where they can handle the heat released..
 8. Do not install on a wall behind a door.
 9. Make sure that the unit is placed in a location where it will not tip over.
 10. Allow at least 3 feet (0.9 m) of clearance between the front of the appliance and any combustible materials such as pillows, sheets, paper, clothing and curtains, and keep them away from the sides and back of the product.
 11. This heater contains hot parts that generate electric arcs or sparks. The unit is not designed to be used or stored in areas that are wet or contain flammable liquids, combustible materials or corrosive, abrasive, chemical or explosive products such as, but not limited to, paint, gasoline, chlorine, sawdust and cleaning products. Store the unit in a dry place when not in use.
 12. Do not route the cord under rugs, hallway runners or other floor coverings or under furniture or appliances. Do not place the unit where it may cause a person to trip over it, or where it may be stepped on or damaged. To prevent the cord from being pinched or damaged, route it where there is little traffic and unplug it when not in use.
 13. Always plug the unit directly into a wall outlet. Do not use an extension cord as it may overheat and cause a fire. Make sure that the unit's power cord connector is securely inserted into the bottom of the electrical outlet before using the unit. If the plug is on the ceiling, it is recommended that the connector be secured to the socket with an appropriate fastening system.
 14. Protect the heater with the appropriate circuit breaker or fuse, in accordance with the nameplate.
 15. Make sure the line voltage (volt) is consistent with the one indicated on the unit's nameplate.
 16. This unit must be grounded. To disconnect heater, turn controls off, and turn off power to heater circuit at main disconnect panel.
 17. This unit is not designed for use in bathrooms, laundry rooms or similar indoor spaces. Never place the unit where it could fall into a bathtub or another type of water container. Do not use it if any part has been submerged. Moreover, do not turn it on or off while your feet are in water or your hands are wet.
 18. When starting up the heater for the first time or after a long period, it is normal that it produces some temporary odours and whitish smoke.
 19. Because this unit is hot when in use, it may pose risks even in normal operation. Therefore, be **careful** and **responsible** when using it. To avoid burns, do not let bare skin touch hot surfaces and use the unit's handle to carry it if possible. The unit must cool down for a few minutes since it will stay warm for some time after shut down.
 20. Extreme caution is necessary when the heater is used by or near a child or invalids and whenever the heater is left operating and unattended.
 21. Do not insert or allow foreign objects to enter any ventilation or exhaust opening in any manner as this may damage it and cause electric shock or fire.
 22. To prevent a possible fire, do not block air intakes or exhaust in any manner. Do not use the unit on soft surfaces, such as a bed, where air inlets and outlets may be blocked, as such an obstruction would cause overheating, which could result in a fire.
 23. Some areas are dustier than others. Thus, it is the user's responsibility to evaluate if the unit must be cleaned based on the amount of dirt accumulated on and inside air vents. Accumulated dirt can lead to a component malfunction or give a yellowish colour to the unit. Failure to install and maintain the unit in accordance with these instructions poses a fire hazard.
 24. Thermal protection activation indicates that the unit has been subjected to abnormal operating conditions. If the thermal protection remains activated it is recommended that a qualified electrician or a certified repair centre examine the unit in order to make sure it is not damaged. (Refer to the limited warranty.)
 25. Make sure that the unit's power cord is not damaged (discoloured, rusted, deformed, etc.). It is important to inspect the cord and plug at least once a year or even once a month if the unit is used on a construction site.
 26. If the unit or his power cord is damaged or defective, discontinue use, cut off power supply at circuit breaker or fuse and have it repaired at a certified repair centre. (Refer to the limited warranty.)
- Recommended heating capacity: 1.25 W/ft³ (0.03 m³). This is equivalent to 10 W/ft² (0.09 m²) for a standard ceiling height of 8 ft (2.44 m). The recommended power is usually sufficient for normal heating needs. Please note that the quality of insulation of walls and windows is a factor that influences heat loss and impacts the power required to heat a room. If necessary, refer to a specialist (in industrial and commercial buildings) who can calculate these heat losses and determine the optimal power required or consult the Stelpro website. If the power of the unit is insufficient for the size of the room, it will run continuously, causing it to age prematurely.
- Note: When part of the product's technical specifications need to be modified to improve handling or other functions, priority is given to the product's technical characteristics. In this case, the instructions may not fully correspond to all the product functions presented. Therefore, the product and its packaging, as well as its name and illustration, may differ from those presented in this manual.

SAVE THESE INSTRUCTIONS

**TAKE A FEW MINUTES TO READ THE HEATER'S INSTALLATION GUIDE
TO ENSURE AN EASY AND SAFE INSTALLATION.**

WHAT'S IN THE BOX

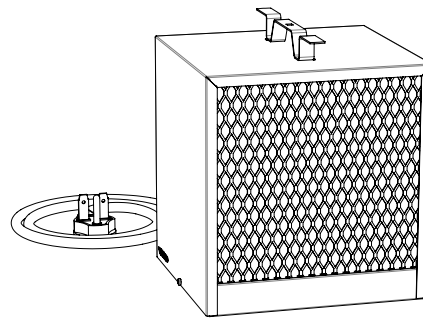

UCH48T MODEL

INSTALLING THE PORTABLE HEATER

1 CONNECTING YOUR PORTABLE HEATER

CAUTION: To avoid any risk of overheating and fire, leave a minimum of 36 in. (91.5 cm) of free space in front of the unit and 6 in. (15 cm) on each side of the unit.

Do not allow objects or furniture such as, but not limited to, pillows, sheets, paper, clothing, curtains, etc., to come in contact with the heater and keep them at a distance of at least 36 in. (91.5 cm) from it.

The unit is not intended for use or storage in damp areas or areas containing flammable liquids, combustible materials and corrosive, abrasive, chemical or explosive products such as, but not limited to, paint, gasoline, chlorine, sawdust and cleaning products.

Make sure that any objects or furniture near the heater can withstand the heat it gives off.

Make sure that the voltage and amperage listed on the back of the unit are compatible with the power supply. Respect all other indications on the nameplate.

Make sure the power cord is securely plugged into an outlet before use. If the outlet is on the ceiling, it is recommended to secure the plug to the outlet using an appropriate fastening system.

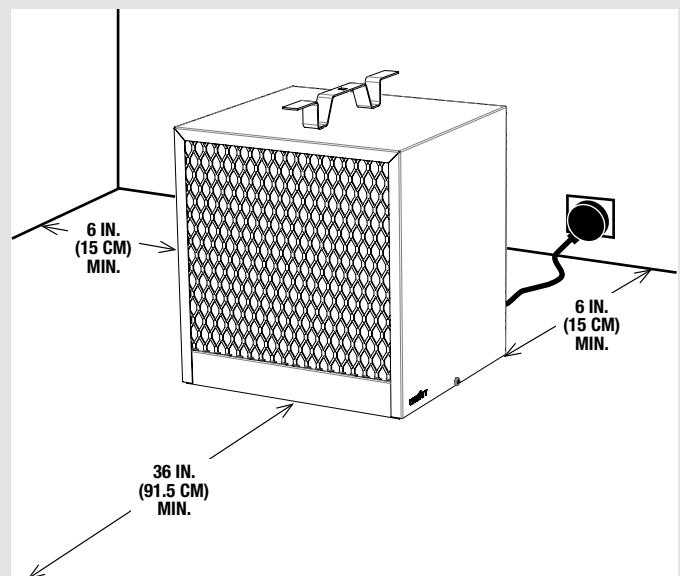

1. Place the unit on a stable horizontal surface.
2. Connect the unit to a properly grounded power supply.

USING THE HEATER

Once the unit is installed, the built-in thermostat allows you to turn off or control the heating temperature.

1. Turn the knob fully clockwise [A] to turn the unit on.
2. When the desired room temperature is reached, turn the thermostat's knob counterclockwise [B] until the unit turns off.
3. To increase the temperature set point, turn the thermostat's knob clockwise.

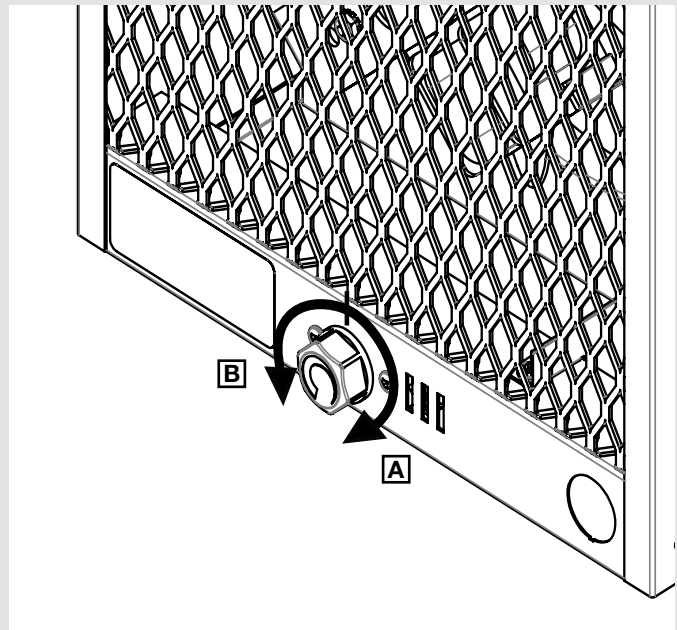

MAINTAINING THE HEATER

THE HEATER'S AIR INLET AND OUTLET MUST BE CLEANED REGULARLY FOR THE WARRANTY TO BE VALID.

WARNING: Turn off the power to the heater directly from the electrical panel before cleaning. Even when it is not heating, the fan heater remains powered on and can cause an electric shock.

Wrap the power cord around the unit's handle when it is unplugged and has cooled down.

Dust the front panel with a soft cloth and clean it with a damp cloth only. If you use cleaning products, they could damage the fan heater.

If the unit is in a very dusty area, use a vacuum cleaner with a dust brush to remove dust and other foreign matter from the unit.

During maintenance, never use the following:

- Metal brush or scouring pad
- Chlorine
- Cleaning products containing abrasives
- Hydrochloric-acid based products, such as bleach
- Any other cleaning product with the following symbols:



TROUBLESHOOTING THE HEATER

The following table lists the most common problems and alerts you may encounter with your heater.

If your issue isn't listed in this table or if the proposed solution does not solve the problem, please turn off the unit and contact our customer service team.

WWW.STELPRO.COM
CONTACT@STELPRO.COM
1-844-STELPRO

PROBLEMS/ALERTS	POSSIBLE CAUSES AND SOLUTIONS
The fan heater doesn't start after it is installed.	<ul style="list-style-type: none"> • Make sure the thermostat is turned on. • Make sure the power cord is securely plugged into an outlet and that the outlet is powered. Make sure that the cable is not damaged. • Make sure the circuit breaker for the heating system on the electrical panel is close (ON). • If none of the above solutions work, an internal component may be defective. Contact Stelpro Customer Service.
The circuit breaker trips when the fan heater is switched on.	<ul style="list-style-type: none"> • Make sure the electrical voltage supplied corresponds to that indicated on the nameplate. • Make sure that the circuit-breaker or fuse is adequate for the power required.
The fan heater operates continuously.	<ul style="list-style-type: none"> • Make sure the unit is powerful enough for the size of the room. • If none of the above solutions work, an internal component may be defective. Contact Stelpro Customer Service.
Heating stops, but the fan continues to operate.	<ul style="list-style-type: none"> • The unit may have overheated, and the thermal protection has been activated. • Make sure the unit's air inlet and outlet are not obstructed. • If none of the above solutions work, an internal component may be defective. Contact Stelpro Customer Service.
The housing becomes extremely hot.	<ul style="list-style-type: none"> • Make sure the unit's air inlet and outlet are not obstructed. • If none of the above solutions work, an internal component may be defective. Contact Stelpro Customer Service.
The fan stops, but heating continues.	<ul style="list-style-type: none"> • Make sure that the fan blades aren't jammed. • If none of the above solutions work, an internal component may be defective. Contact Stelpro Customer Service.

STELPRO LIMITED WARRANTY

This limited warranty is offered by Stelpro Design Inc. ("Stelpro") and applies to the following product made by Stelpro: model **UCH**.

Please read this limited warranty carefully. Subject to the terms of this warranty, Stelpro warrants its products and their components against defects in workmanship and/or materials for the following periods from the date of purchase: **2 years**. This warranty applies only to the original purchaser; it is non-transferable and cannot be extended.

CLAIM PROCEDURE

If at any time during the warranty period the unit becomes defective, you must cut off the power supply at the main electrical panel and contact 1) your installer or distributor, 2) your service center or 3) Stelpro's customer service department. In all cases, you must have a copy of the invoice and provide the information written on the product nameplate. Stelpro reserves the right to examine or to ask one of its representatives to examine the product itself or any part of it before honoring the warranty. Stelpro reserves the right to replace the entire unit, refund its purchase price or repair a defective part. Please note that repairs made within the warranty period must be authorized in advance in writing by Stelpro and carried out by persons authorized by Stelpro.

Before returning a product to Stelpro, you must have a Stelpro authorization number (RMA). To obtain it, call the customer service department at: 1-844-STELPRO. The authorization number must be clearly written on the parcel or it will be refused.

CONDITIONS, EXCLUSIONS AND DISCLAIMER OF LIABILITY

This warranty is exclusive and in lieu of all other representations and warranties (except of title), expressed or implied, and Stelpro expressly disclaims and excludes any implied warranty of merchantability or implied warranty of fitness for a particular purpose.

Stelpro's liability with respect to products is limited as provided above. Stelpro shall not be subject to any other obligations or liabilities whatsoever, whether based on contract, tort or other theories of law, with respect to goods or services furnished by it, or any undertakings, acts or omissions relating thereto. Without limiting the generality of the foregoing, Stelpro expressly disclaims any liability for property or personal injury damages, penalties, special or punitive damages, damages for lost profits, loss of use of equipment, cost of capital, cost of substitute products, facilities or services, shut-downs, slowdowns, or for other types of economic loss or for claims

of a dealer's customers or any third party for such damages. Stelpro specifically disclaims all consequential, incidental and contingent damages whatsoever.

This warranty does not cover any damages or failures resulting from: 1) a faulty installation or improper storage; 2) an abusive or abnormal use, lack of maintenance, improper maintenance (other than that prescribed by Stelpro) or a use other than that for which the unit was designed; 3) a natural disaster or an event out of Stelpro's control, including, but not limited to, hurricanes, tornadoes, earthquakes, terrorist attacks, wars, overvoltage, flooding, water damages, etc. This warranty does not cover any accidental or intentional losses or damages, nor does it cover damages caused by negligence of the user or owner of the product. Moreover, it does not cover the cost of disconnection, transport, and installation.

The warranty is limited to the repair or the replacement of the unit or the refund of its purchase price, at the discretion of Stelpro. Any parts replaced or repaired within the warranty period with the written authorization of Stelpro will be warranted for the remainder of the original warranty period. This warranty will be considered null and void and Stelpro will have the right to refuse any claims if products have been altered without the written authorization of Stelpro and if the nameplate numbers have been removed or modified. This warranty does not cover scratches, dents, corrosion or discoloration caused by excessive heat, chemical cleaning products and abrasive agents. It does not cover any damage that occurred during the shipping.

Some states and provinces do not allow the exclusion or limitation of incidental or consequential damages and some of them do not allow limitations on how long an implied warranty lasts, so these exclusions or limitations may not apply to you. This warranty gives you specific legal rights and you may have other rights which vary from state to state or from province to province.

THANK YOU FOR YOUR PURCHASE!
NEED ASSISTANCE? CONTACT STELPRO CUSTOMER SERVICE.

WWW.UNIWATT.CA
CONTACT@STELPRO.COM
1-844-STELPRO

UNIWATT is a line of products manufactured by STELPRO.
For more information, please contact customer service.

STELPRO DESIGN INC.
Saint-Bruno-de-Montarville, Québec, Canada, J3V 6L7