

# UNIWATT™

UGB ELECTRIC BASEBOARD

1-844-STELPRO  
WWW.UNIWATT.CA

## IMPORTANT INSTRUCTIONS

When using electrical appliances, basic precautions should always be followed to reduce the risk of fire, electric shock, and injury to persons, including the following:

1. Read all instructions before using this heater.
2. A heater has hot and arcing or sparking parts inside. Do not use it in areas where gasoline, paint, or flammable liquids are used or stored.
3. This heater is hot when in use. To avoid burns, do not let bare skin touch hot surfaces. If provided, use handles when moving this heater. Keep combustible materials, such as furniture, pillows, bedding, papers, clothes, and curtains away from heater.
4. To prevent a possible fire, do not block air intakes or exhaust in any manner. Do not use on soft surfaces, like a bed, where openings may become blocked.
5. Do not insert or allow foreign objects to enter any ventilation or exhaust opening as this may cause an electric shock or fire, or damage the heater.
6. This product must be installed by a qualified person and connected by a certified electrician, according to the electrical and building codes effective in your region and NEC.

The following instructions must be adhered to avoid personal injuries or property damages, serious injuries and potentially fatal electric shocks.

7. Protect the heating unit with the appropriate circuit breaker or fuse, in accordance with the nameplate.
8. Make sure the line voltage (volt) is consistent with that indicated on the unit's nameplate.
9. This unit must be grounded.
10. Switch off the power at the circuit breaker/fuse before installing, repairing and cleaning the unit.
11. Make sure the unit is appropriate for the intended use (if needed, refer to the product catalog or a representative).
12. Do not install the unit where objects or furniture could be damaged by the heat.
13. Respect distances and positions indicated in the installation section.
14. If the installer or user modifies the unit, they will be held responsible for any damage resulting from this modification, and the CSA/UL certification could be void.
15. When starting up the unit for the first time or after a long period, it is normal that it produces some temporary odours and whitish smoke.
16. Do not install on a wall behind a door.
17. Make sure the electrical connections are sturdy and have been executed correctly. Failure to comply with this directive could result in a fire.

## SAVE THESE INSTRUCTIONS

**MATERIAL REQUIRED:** Flat and Phillips screwdrivers, screws, twist-on wire connectors, wire strippers, cable clamp connector.

EN1

## INSTALLATION

### CAUTION

1. Do not install heater in any position other than as shown in this manual.
2. Wiring procedures and connections should be in accordance with the National Electrical Code (NEC) and local codes.
3. To reduce the risk of fire, do not store or use gasoline or other flammable vapors and liquids in the vicinity of the heater.
4. Do not install heaters against combustible low-density cellulose fiberboard surfaces.
5. Do not install heaters below an electrical convenience receptacle.
6. Use only with copper branch circuit conductors.
7. CAUTION – High temperature, keep electrical cords, drapes, and other furnishings away from heater.
8. Keep drapes at a distance of at least 6 in. (15 cm) from unit.
9. Do not install unit in contact with combustible materials.
10. Do not remove or bypass the thermal protection [G].

To ensure safe operation of the heating unit, the clearance specifications shown in the drawing below must be met.

### CLEARANCE REQUIRED

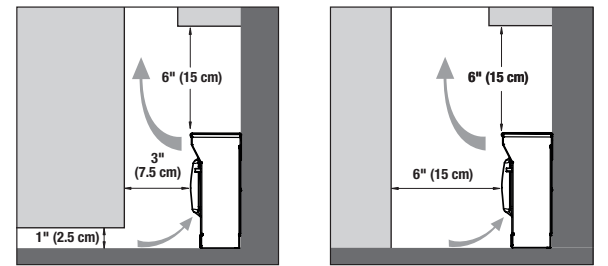

## 1 PREPARING THE BASEBOARD

**WARNING: Turn off the power supply.**

1. Remove the junction box cover [A].
2. Remove one of the knockouts in the wiring compartment [B].
3. Install a cable clamp connector (not included). Pull power cable supply through the cable clamp connector leaving at least 6 in. (15 cm) of wire leads.

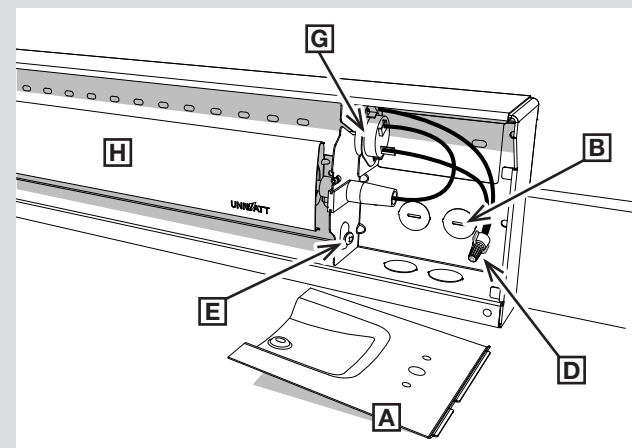

EN2

## INSTALLATION - CONTINUED

## 2 CONNECTING THE WIRING

1. Connect the grounding wire firmly with the green screw [E] provided.
2. Connect the baseboard and power supply wires [C] according to the connection diagram. Tighten wires into the twist-on connectors [D] to make sure the connections are secure before pushing them back into the junction box.
3. Screw the junction box cover [A] back on.

### WIRING DIAGRAM: ONE BASEBOARD

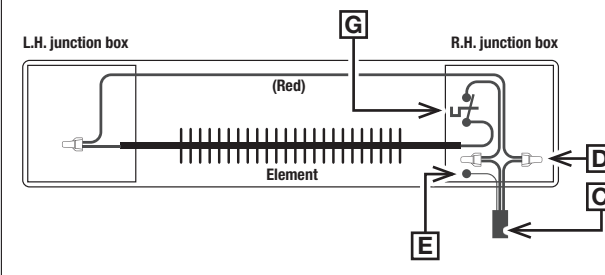

### WIRING DIAGRAM: MULTIPLE BASEBOARDS

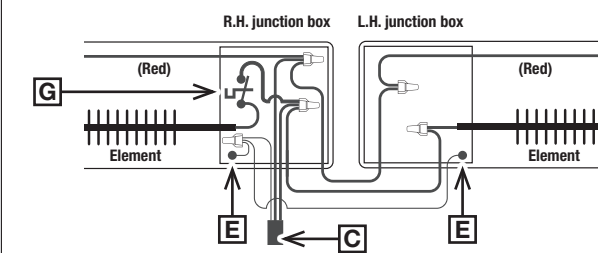

### NET VOLUMES (cm³)

JUNCTION BOX	WITHOUT THERMOSTAT	WITH THERMOSTAT
Left	691.04	N/A
Right	681.05	628.94

## 3 ATTACHING THE BASEBOARD TO THE WALL

1. Attach the baseboard to the wall using at least four (4) mounting holes [F]. If no studs are available, anchors may be required. Do not over tighten.

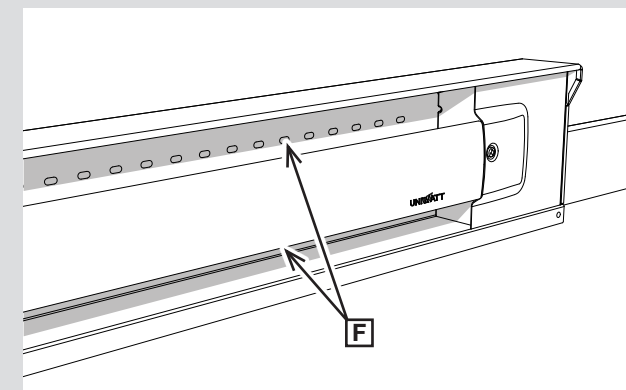

EN3

## OPERATION AND MAINTENANCE

**WARNING: The baseboard must be properly installed before it is used. Fins are sharp and may cause cuts, do not touch.**

1. Once a year, or as required, use a damp cloth and non-abrasive dish soap to remove any dust build-up. All other servicing is to be done by qualified service personnel.
2. Before cleaning, make sure the power has been turned off at the circuit breaker panel, and wait until the elements have cooled before cleaning the unit or removing the front cover.
3. If the unit is installed in a dusty area, use a vacuum cleaner to remove the dust.
4. Replace front cover [H] if it was removed.
5. Restore the power at the circuit breaker.

## STELPRO LIMITED WARRANTY

This limited warranty is offered by Stelpro Design Inc. ("Stelpro") and applies to the following product made by Stelpro: model UGB. Please read this limited warranty carefully. Subject to the terms of this warranty, Stelpro warrants its products and their components against defects in workmanship and/or materials for the following periods from the date of purchase: **2 years** and **10 years warranty on the heating element (for first end user)**. This warranty applies only to the original purchaser; it is non-transferable and cannot be extended.

### CLAIM PROCEDURE

If at any time during the warranty period the unit becomes defective, you must cut off the power supply at the main electrical panel and contact 1) your installer or distributor, 2) your service center or 3) Stelpro's customer service department. In all cases, you must have a **copy of the invoice** and provide the **information written on the product nameplate**. Stelpro reserves the right to examine or to ask one of its representatives to examine the product itself or any part of it before honoring the warranty. Stelpro reserves the right to replace the entire unit, refund its purchase price or repair a defective part. Please note that repairs made within the warranty period must be authorized in advance in writing by Stelpro and carried out by persons authorized by Stelpro.

Before returning a product to Stelpro, you must have a Stelpro authorization number (RMA). To obtain it, call the customer service department at: **1-844-STELPRO**. The authorization number must be clearly written on the parcel or it will be refused.

### CONDITIONS, EXCLUSIONS AND DISCLAIMER OF LIABILITY

This warranty is exclusive and in lieu of all other representations and warranties (except of title), expressed or implied, and Stelpro expressly disclaims and excludes any implied warranty of merchantability or implied warranty of fitness for a particular purpose.

Stelpro's liability with respect to products is limited as provided above. Stelpro shall not be subject to any other obligations or liabilities whatsoever, whether based on contract, tort or other theories of law, with respect to goods or services furnished by it, or any undertakings, acts or omissions relating thereto. Without limiting the generality of the foregoing, Stelpro expressly disclaims any liability for property or personal injury damages, penalties, special or punitive damages, damages for lost profits, loss of use of equipment, cost of capital, cost of substitute products, facilities or services, shutdowns, slowdowns, or for other types of economic loss or for claims of a dealer's customers or any third party for such damages. Stelpro specifically disclaims all consequential, incidental and contingent damages whatsoever.

This warranty does not cover any damages or failures resulting from: 1) a faulty installation or improper storage; 2) an abusive or abnormal use, lack of maintenance, improper maintenance (other than that prescribed by Stelpro) or a use other than that for which the unit was designed; 3) a natural disaster or an event out of Stelpro's control, including, but not limited to, hurricanes, tornadoes, earthquakes, terrorist attacks, wars, overvoltage, flooding, water damages, etc. This warranty does not cover any accidental or intentional losses or damages, nor does it cover damages caused by negligence of the user or owner of the product. Moreover, it does not cover the cost of disconnection, transport, and installation.

The warranty is limited to the repair or the replacement of the unit or the refund of its purchase price, **at the discretion of Stelpro**. Any parts replaced or repaired within the warranty period with the written authorization of Stelpro will be warranted for the remainder of the original warranty period. This warranty will be considered null and void and Stelpro will have the right to refuse any claims if **products have been altered** without the written authorization of Stelpro and if the nameplate numbers have been removed or modified. This warranty does not cover scratches, dents, corrosion or discoloration caused by excessive heat, chemical cleaning products and abrasive agents. It does not cover any damage that occurred during the shipping.

Some states and provinces do not allow the exclusion or limitation of incidental or consequential damages and some of them do not allow limitations on how long an implied warranty lasts, so these exclusions or limitations may not apply to you. This warranty gives you specific legal rights and you may have other rights which vary from state to state or from province to province.